

Comparison of SMR and SCP training employing a newly developed discrete-trial based biofeedback system

Implications for Brain-Computer Interfaces, Neurofeedback and the interrelationship between SCP and SMR networks

Michiel Kleinnijenhuis

Thesis M.Sc. Cognitive Neuroscience

Radboud Universiteit Nijmegen

October 2007

Supervisor: Drs. M.W. Arns

Tutor: Prof. dr. J. Duysens



Radboud Universiteit Nijmegen



Abstract

Background

Operant conditioning of one's slow cortical potential (SCP) or sensorimotor rhythm (SMR) can be used to control epilepsy or to manipulate external devices, as applied in BCI (Brain-Computer Interface). To be practical, a BCI-system should use as less channels as possible. For this purpose, a wireless biofeedback system was developed that allows feedback of a single EEG-channel in discrete trials. The commonly accepted view that both the SCP and SMR are a reflection of central arousal suggests a functional relationship between SCP and SMR networks.

Methods

A training was performed that aimed to teach 19 participants to control their SCP (n=9) or SMR (n=10) over vertex. Participants received 20 neurofeedback sessions, each comprising of 96 trials in which they had to decrease cortical arousal (SCP positivity/SMR enhancement) and 64 trials in which they had to increase cortical arousal (SCP negativity/SMR suppression). In a trial, participants were required to exceed an individual threshold level of the feedback parameter relative to a 500 ms pre-feedback baseline and hold this level for 2 seconds (SCP) or 0.5 seconds (SMR) in order to obtain reinforcement.

Results

Overall, 10 of the total of 19 participants achieved control over their EEG. In the SCP-trained group, 4 out of 9 participants were able to increase the differentiation between their SCP responses on positivity-required vs. negativity-required trials over the course of the experiment. Improvements in control over the SMR in suppression-required and enhancement-required trials were acquired by respectively 3 and 4 of the 10 SMR-trained participants. These SMR-trained responders did not show *differentiation* between their SMR responses in enhancement-required vs. suppression-required trials. Interestingly, the SMR responders did show a differentiation in their *SCP* response while trained on SMR.

Conclusions

It can be concluded from this experiment that, with the proposed method, a number of the participants are able to acquire control over their SCP or SMR. For SMR, however, bidirectional control is very difficult to achieve with the present training procedure. Furthermore, SCP positivity and SMR enhancement are easier to learn compared to their counterparts. The observed SCP differentiation while training *SMR* and absence of equivalent SMR changes while training *SCP* suggest that SMR training modulates the central arousal system, whereas SCP training invokes local effects.

Keywords

brain-computer interface, epilepsy, slow cortical potential, sensorimotor rhythm, neurofeedback, discrete training.

Acknowledgments

This project was funded by the BIAL foundation (grant number 163/04).

I would like to express my gratitude to my supervisors for their support during this project. First, I would like to thank Martijn Arns for giving me the opportunity to perform this research at Brainquiry and for his always enthusiastic contributions. Second, I would like to thank Jacques Duysens for the valuable reflections, for sharing his scientific expertise and for keeping my attitude a positive one. Third, I thank Stan Gielen for his role in the first stages of the project and his contributions to the manuscript.

To my colleagues at Brainquiry, Brain Resource Company and EEG Resource Institute I owe a big thanks for keeping me motivated throughout the project. I really appreciated your support, your company and the conversations during lunch. In the context of this project, I would like to specifically mention Erica Schot-Heesen for her support in the initial phase of the study, Rien Breteler for his input in methodological issues and Noemí Sánchez Náchter for her extensive contribution to the training of the participants.

Furthermore, I would like to thank all participants for enduring the 'torments' of the training with so much optimism. The advice of Vivian Weerdesteyn and Fred Hasselman on the statistics was highly appreciated.

Finally, I would like to deeply thank Desirée Spronk; the main contributor and my most valuable 'result' of the project. Thank you for all the fun and moments of happiness we had working together on this project!

Introduction

In neurofeedback, self-regulation of brain activity can be acquired by means of real-time feedback on EEG parameters. The feedback is administered by representing certain appropriate characteristics of the EEG in the visual, auditory or tactile modality. The task of brain activity self-regulation is thereby converted into regulation of the representation thereof. The neurofeedback method can be used for the treatment of a large number of brain disorders including ADD/ADHD (Monastra et al., 2005; Lubar et al., 1995; Vernon et al., 2003), epilepsy (Kotchoubey et al., 2001; Sterman & Shouse, 1980), autism (Scolnick, 2005), Tourette's syndrome (Tansey, 1986), anxiety (Hardt & Kamiya, 1978; Hammond, 2005) and depression (Baehr et al., 2001).

The present study investigates the feedback of two EEG parameters, the sensorimotor rhythm (SMR) and the slow cortical potential (SCP). The sensorimotor rhythm is an expression of synchronized oscillatory activity originating from the pyramidal cells in layer IV of the sensorimotor cortex. The frequency of oscillation is individually variable, but mostly falls within the range of 12-15 Hz. The SMR is initiated by the absence of efferent motor and afferent somatosensory activity (Sterman, 2000). Slow cortical potentials (SCP's) are positive or negative DC potentials generated in the brain that are filtered out of the EEG in most applications. The SCP is a reflection of the depolarization of apical dendrites of pyramidal cells in the cortex (Birbaumer et al., 1990). A SCP shift, therefore, signals a change in cortical excitability. The topography of the SCP reflects the activation of distinct cortical cell assemblies while the amplitude of the negative maximum seems to reflect how much a particular cell assembly is activated at a particular time (Rösler et al., 1997).

Since both the slow cortical potential (Nagai et al., 2004b) and the sensorimotor rhythm (Sterman, 1982) can be regarded as measures of cortical arousal, it can be hypothesized that they are an expression of the same underlying phenomenon. The generating mechanisms of both SCP and SMR are relatively well understood (Birbaumer et al., 1990; Sterman, 2000), but do not suggest a direct link between the two parameters. This, however, does not exclude the possibility that both SCP and SMR can be modulated by a common source (i.e. arousal, attention) and influence one another through this common mechanism. This proposed functional relationship could be

revealed by co-registration of the SCP and SMR while training these in a neurofeedback training protocol.

The first report of successful self-regulation of the SMR was in an epileptic patient (Stermán & Friar, 1972). Elaborating on Stermán's studies with cats – that were operantly conditioned to increase their sensorimotor rhythm in a previous experiment and thereby turned out to be less prone to hydrazine-induced seizures than non-conditioned cats (Wyrwická & Stermán, 1968) – EEG operant conditioning was used to increase the SMR in an epileptic patient and a clinically advantageous effect was demonstrated by a significant reduction in seizure frequency after neurofeedback training. In this study, a 23 year old drug-refractory patient with a 7 year history of generalized tonic-clonic seizures was subjected to neurofeedback training twice a week for three months. A study of her EEG revealed 5-7 Hz slowing and spike activity, but no localized lesions were found. Her symptoms included lateral eye deviations, tonic-clonic movements, loss of consciousness and incontinence. A consistent pattern of two major motor seizures every month was observed over several years, mostly occurring at night. The EEG operant conditioning training employed light and auditory rewards for an increase of activity in the 11-15 Hz frequency band over the sensorimotor strip. Post-training quantitative EEG analysis showed a significant increase in the 11-15 Hz power. More importantly, the patient almost ceased to have any seizures. Stermán and other groups replicated this result in several group studies employing a variety of controls (Stermán et al., 1974; Finley et al., 1975; Seifert & Lubar, 1975; Tozzo et al., 1988; see Stermán, 2000 for a review).

Stermán proposed that the mechanism for this seizure reduction is an improved control over excitability levels in the thalamocortical loop that produces the SMR (Stermán, 2000). The SMR originates from the ventrobasal nuclei of the thalamus. These nuclei show slow depolarization in case of reduced somatosensory information relay. The reticular nucleus responds to the depolarization with a GABAergic inhibition of the ventrobasal nuclei causing a rehyperpolarization which, in turn, initiates a new depolarization. The resulting bursts of activity are relayed to the sensorimotor cortex and are expressed as the SMR in the EEG (Bazhenov et al., 1999). The coincidence of bursts of afferent input to the sensorimotor pyramidal cells and depolarization of these cells through horizontal connections within the cortex facilitates long term potentiation

(Malenka & Nicoll, 1999). Therefore, learning to increase the SMR is optimal when the patient is actively engaged in the task (Sterman & Egner, 2006).

Not all studies support this proposed mechanism. Several authors argued that the reduction in seizures by EEG operant conditioning was not caused by 12-15 Hz enhancement per se, but was related to general EEG desynchronization or the inhibition of slow frequencies. Kuhlman (1978) reinforced 9-14 Hz activity sequentially in 12 sessions of non-contingent (EEG record of the previous session) and 24 sessions of contingent feedback in 5 epilepsy patients. No significant reduction in seizures was observed after the non-contingent feedback sessions. After the contingent feedback sessions, however, 3 patients achieved a seizure reduction of 60 %, on average. This paradigm excluded non-specific and placebo effects as a cause of the seizure reduction, but in this study no evidence was found for the hypothesis that the seizure reduction is specific to the reinforcement of SMR frequencies since no changes were found in these frequencies. This is in agreement with the results of Wyler et al. (1976) who found a seizure reduction in 4 out of 4 patients when reinforcing 18-23 Hz while inhibiting 1-14 Hz and EMG activity, but not in controls receiving non-contingent feedback.

These criticisms were countered by Sterman & McDonald (1978) by employing an ABA crossover design. One group of 4 patients was subjected to an operant conditioning protocol employing 12-15 Hz and 6-9 Hz frequencies and another group of 4 patients was subjected to a 18-23 Hz and 6-9 Hz protocol. In the first three months of training the 12-15 Hz/18-23 Hz activity was reinforced while the 6-9 Hz activity was inhibited. In the following three months, reward contingencies were reversed, reinforcing 6-9 Hz activity and suppressing 12-15 Hz/18-23 Hz. In the final period the contingencies reversed again. The results showed that the reward rates increased with training and dropped upon reversal of reward contingencies, indicating acquisition of control over the trained EEG frequencies for both groups. For the 12-15 Hz group, seizure rates decreased significantly in the first phase of training when 12-15 Hz was reinforced. In the second phase –inhibiting 12-15 Hz– seizure rates returned to the pre-intervention baseline. After the second reversal seizure rates decreased again to below the level attained after the first three month period. The 18-23 Hz group showed a gradually decreasing seizure rate throughout the three training phases. Results of a power spectral density analysis of NREM polysomnography of four frequency bands indicated that in the 12-15 Hz group,

the first training phase led to an increased power in the 8-11 Hz and 12-15 Hz frequency bands and an increase in the 0-3 Hz and 20-23 Hz frequency bands. This effect was reversed when reward contingencies were reversed and once again reversed on the second contingency switch. The 18-23 Hz group showed a different pattern. The 0-3 Hz and 20-23 Hz bands showed a continuous decline in power, whereas the 8-11 Hz and 12-15 Hz power showed a continuous increase (Sterman & Shouse, 1980). This experiment related a reduction in seizure rate to a reduction in 0-3 Hz and/or 20-23 Hz power and an increase in the power of intermediate 8-15 Hz frequencies. It also showed that seizure reduction is specific for training aimed at increasing the topographically located SMR, but not for training higher frequencies on the sensorimotor strip.

Apart from the sensorimotor rhythm, neurofeedback on other EEG characteristics has also proven to be advantageous for epilepsy patients. Rockstroh et al. (1993) investigated the effect of neurofeedback training of slow cortical potentials on the symptoms of epilepsy patients. They subjected 25 patients to a training procedure in which the patients were learnt to regulate their SCP's. Depending on the discriminative stimulus, the patients had to shift their SCP in either a negative or positive direction within an 8 s trial. In feedback trials, the integrated SCP recorded from Cz relative to a 4 s pre-trial baseline was represented as the position of a rocket ship on a TV screen. In transfer trials only the discriminative stimulus was presented. The training consisted of 28 sessions each containing 60 feedback trials and 50 transfer trials. Seventeen out of 25 patients showed a significant differentiation between their SCP response in the positivity required vs. negativity required trials. The extent of differentiation showed a cubic trend over the sessions. The comparison of seizure frequency records of an 1-year follow-up period to an 8 week pre-training baseline indicated a significantly reduced median seizure frequency in the follow-up period. Six patients became seizure free in this period and seven patients showed reduced seizure frequency, while in five patients no change in seizures was observed.

Birbaumer et al. (1990) proposed that the mechanism of SCP neurofeedback seizure reduction is an improved control over cortical excitability. Negative SCP shifts reflect an increase in excitability of the cortex, whereas positive SCP's reflect a decrease in cortical excitability (Elbert, 1993). Negative SCP's and paroxysmal depolarization shifts in cortical neurons occur simultaneously (Ikeda et al., 1999). Further, negative SCP's reflect

widespread depolarization of apical dendrites and decreased thresholds of paroxysmal activity (Birbaumer et al, 1990). Since epilepsy is a disturbance in neuronal excitability that is characterized by widespread paroxysmal depolarization shifts, it is to be expected that a suppression of cortical negativity will reduce seizure incidence. Further evidence for the expression of lowered excitability thresholds in negative SCP shifts is the finding that epileptics can produce a negative potential shift by means of hyperventilation, a common technique to induce a seizure. Moreover, it was shown that this induced negative SCP shift is reduced by anti-epileptic medication (Rockstroh et al., 1993).

A second application of neurofeedback methodology is in the field of brain-computer interfacing (BCI). BCI is a technique that uses signals extracted from the brain to control devices (computers) without muscular activity or overt speech. Such control can be beneficial for patients with severe motor disabilities. For example, the BCI technique is currently employed by patients suffering from amyotrophic lateral sclerosis (ALS; Kübler et al., 1999). These patients suffer from a degenerative disease, that causes them to gradually lose all muscular activity because the condition destroys their motor pathways. The disease leaves the afferent pathways intact. ALS patients therefore have full sensational capabilities and, moreover, have normal brain function. In the advanced stage of the disease, patients are left with no way to communicate ('locked-in' syndrome). BCI is a very useful tool that opens possibilities to these patients to interact with their environment. One system that was developed for ALS patients is the Thought Translation Device (TTD). It was developed by Birbaumer and colleagues (Birbaumer et al., 1999). The TTD uses self-regulation of the slow cortical potential (SCP) as a means of a binary decision strategy. By either increasing or decreasing the SCP relative to a pre-trial baseline the patient can choose between selections of letters of the alphabet until the desired letter is selected. With this method, patients can achieve a spelling speed of approximately four characters per minute.

Birbaumer et al. (1999) learned two ALS patients to voluntarily control their SCP's. Both patients were in the advanced stage of the disease, implying that they were artificially respirated and fed for more than four years and they had no controlled muscle function left. By means of EEG operant conditioning, the patients were taught to move a cursor on a computer screen that represented their slow cortical potential. The cursor moved up or down, conditional on the SCP being negative or positive relative to a 2-second pre-

trial baseline SCP level. The patients had to shift their SCP within 2-4 seconds (individually adapted) from trial start to hit either the upper or lower target on the computer screen, depending on which target was highlighted. The trial phases were indicated by distinct tones. The shaping consisted of adapting the response criterion progressively from 5 μ V to 8 μ V. The spelling device was introduced when the patients reached a stable performance of 75 % at the 8 μ V criterion for the positivity-required trials. For both patients, this took approximately 300 sessions (5-10 minutes each, comprising 70-100 trials). After the training, both patients were able to write letters with their newly acquired skill, although this is still very time-consuming at less than one word per minute (Kübler et al, 1999).

Numerous variations on this training protocol have been tested (Kübler et al., 1999; Neumann et al., 2004; Kaiser et al., 2001). Hinterberger et al. (2004) compared the TTD with only the visual feedback modality to an extended version incorporating an auditory feedback modality and a combined modality. Healthy participants (n=54) were randomly assigned to a visual, auditory or combined SCP feedback condition. Participants received 3 sessions of 500 trials. In the visual feedback group, stimulus presentation – trial type indication, feedback and reinforcement – was entirely visual, whereas in the auditory feedback group all stimuli were presented auditorily. In this case the feedback was administered by means of piano tones with a pitch that was proportional to the SCP amplitude. In the combined modality, the trial type indication, feedback and reinforcement were signaled by a combination of the visual and auditory stimuli. The results showed that, next to the visual feedback, the TTD could be operated in both the auditory and combined modality. However, previous findings from Lal et al. (1998) that feedback in the visual modality is best for biofeedback were confirmed. The combined modality of feedback presentation was found to be the least suitable, presumably because learning was impeded by too high attentional load.

Several studies have shown that it is also possible to operate a BCI with rhythmic activity over the sensorimotor cortex (Pfurtscheller et al., 1996; Wolpaw et al., 2002; Kübler et al., 2005). Typically, the mu or beta-rhythms are used. Kübler et al. (2005) reported a study that showed that also ALS patients were able to master the skill of regulating mu and beta rhythms over sensorimotor cortex. They employed the BCI system that was developed by Wolpaw et al. (2002) in four ALS patients. Results indicated that all four

patients were able to exert control over activity over the sensorimotor cortex with an accuracy of over 70 % within 20 sessions.

The regular approach in clinical neurofeedback is to reward desired behavior in a continuous task execution setting (e.g. in a 5 minute run the advancement of a video is dependent on the feedback variable exceeding a certain threshold level). In BCI, however, a discrete trial method is more appropriate. The nature of the goal that is pursued imposes these different approaches. The aim for clinical neurofeedback is to manipulate general levels of EEG characteristics, whereas in BCI a transient EEG response is appropriate for controlling a device. Despite the broadly accepted convention to use continuous tasks in clinical neurofeedback a discrete approach might be a more effective learning method, because it has always been a key feature of the traditional operant conditioning method (Ferster & Skinner, 1957).

In summary, it has been established that people are able to learn to increase and decrease both their sensorimotor rhythm and slow cortical potentials. Moreover, the increase of the sensorimotor rhythm and the decrease of the slow cortical potential have advantageous effects on seizure incidence in epilepsy patients. In addition, control over slow cortical potentials or sensorimotor rhythms can both be used to operate brain-computer interfaces. The learning method that is likely to maximize success should incorporate immediate, contingent visual feedback on the physiological parameter in discrete feedback trials.

Although in recent years significant progress has been made in the field of EEG-based brain-computer interfacing, the systems that are commonly employed are traditional full-cap systems that require a lot of effort to apply and maintain. Some of the latest techniques (spatial filtering, independent component analysis) indeed require a multitude of electrodes to be applied. Since these techniques are so cumbersome the question arises whether a single measurement electrode could be sufficient, and therefore allow BCI-systems that are more applicable and easy to use in practice. Recent advances in technology have resulted in the development of portable wireless EEG equipment that can measure a limited number of channels. It has been shown in tele-neurofeedback – when patients train at home, supervised by their therapist over the internet – that this equipment can be easily applied by end-users that have had only minimal training in application of the electrodes and use of the software (Breteler et al.,

2006). In the light of a BCI that should be applicable in e.g. spinal cord-injured patients it is desirable that the BCI set-up is as simple as possible, such that the end-user is able to apply and operate it with minimal assistance.

Therefore, we started the development of a new system for the feedback of physiological parameters. The present study reports on the first experiences with the newly developed system. In the present experiment we focus on the feedback of the sensorimotor rhythm and slow cortical potentials, since both SMR and SCP control have been proven to be advantageous for epilepsy patients and it has already been shown that the SCP can be used for BCI purposes. This investigation will explore if the 12-15 Hz SMR might also be an EEG frequency suitable for brain-computer interfacing. With this study we want to ascertain whether, with the proposed system, subjects can be trained to control their SCP or SMR. More specifically, the questions we want to address with this study are:

- a) are participants able to voluntarily increase or decrease their SCP or SMR using discrete feedback?
- b) do participants show a change in their SCP or SMR responses over the course of training reflecting improved skill acquisition?
- c) how do the percentages of successful responses of SCP-trained and SMR-trained participants compare over the tasks of increasing and decreasing the SCP or SMR level?
- d) is there evidence for a functional relationship in the networks that generate the SCP and SMR (in other words: do changes occur in one, while subjects are being trained at the other)?

Methods

Participants

Nineteen people (10 female) participated in the experiment. All participants were recruited according to the normative subject profile of the Brain Resource Company (BRC) QEEG database, of which exclusion criteria include a history of neurological, psychiatric or psychological disturbances; motor, hearing or vision impairments and serious medical conditions. Every participant gave informed consent prior to the study. The study was approved by the Institutional Review Board (METC Noord Holland; number M05-010).

Apparatus

Data recording was achieved using personal computers and BioExplorer software. A complex open source design was programmed in the BioExplorer software environment. The design and manual can be downloaded freely from <http://www.brainquiry.nl>. This design allows for the processing of multiple physiological parameters including EEG, EOG and GSR. It features a module for the generation of trial sequences, which is flexible with respect to the durations of the trials, trial phases, inter-trial intervals and trial type randomization. It further includes a module for trial rejection on the basis of aberrant signal characteristics. The design incorporates an EOG-based method for correction of vertical eye-movement influences during the feedback of slow cortical potentials. The software calculates a feedback signal from the selected physiological parameter by extracting the relevant parameter (i.e. SCP, SMR, phasic GSR) from the raw data and subtracting the pre-feedback baseline. The criteria for a two-stage reinforcement, rewarding a specific feedback signal amplitude and duration of maintaining that amplitude, are independently adjustable. A trial counter module tracks the trial outcome (valid vs. invalid; successful vs. unsuccessful) and calculates the success percentages online. The design features an operator window and a feedback window. The operator window allows the experimentator to control the session by showing raw and processed signals and the relevant trial characteristics. The feedback window is presented to the participant and shows the feedback signal, reinforcers, and relevant trial information.

The participants' EEG was recorded from Cz referenced against linked mastoids (A1+A2/2) using the wireless 2-channel bipolar Brainquiry PET SCP with active electrodes. The second channel of the PET SCP was used for recording vertical eye-movement activity (vEOG). The EOG electrodes were placed on the sagittal midline 1 cm above and below the outer canthus of the right eye. The ground electrode was placed on AF3. EEG and EOG were recorded with a sampling frequency of 200 Hz. Disposable pre-gelled Ag/Ag+Cl⁻ electrodes (Arbo electrodes, Tyco) were used for EEG recording. Ten20 electrode paste was applied on the Cz recording site. All electrode sites were prepared with alcohol and Nuprep.

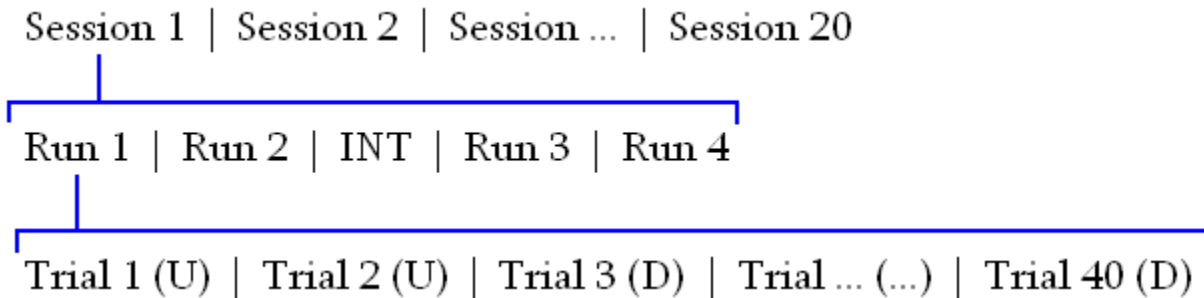

Figure 1. Schematic representation of the course of the training. The experiment spanned a total of 20 training sessions. Every training session consisted of four separate runs of 7 minutes. Between Run 2 and Run 3 there was a short intermezzo of approximately 2 minutes to reflect on the first two runs and to encourage the participant for runs 3-4. A run consisted of 40 trials of which 24 were in the ‘down’ (D) condition and 16 in the ‘up’ (U) condition.

Procedure

The participants received 20 neurofeedback training sessions in which they were trained to self-regulate their slow cortical potential (n=9) or sensorimotor rhythm (n=10). The experiment spanned a total of eight weeks with three training sessions per week with no more than one session per day. The sessions were divided into four runs of 40 discrete trials each. After two runs participants were encouraged and informed on their progress during a 1-2 minute pause (fig. 1). Trials were interleaved by a variable inter-trial-interval (1.5-3 s). Before the experiment, participants were instructed to minimize movement of body, head, hands and eyes. This instruction was repeated if necessary. Before and after every session, participants filled out a questionnaire assessing possible influencing factors. In the trials two conditions were mixed pseudo-randomly with the

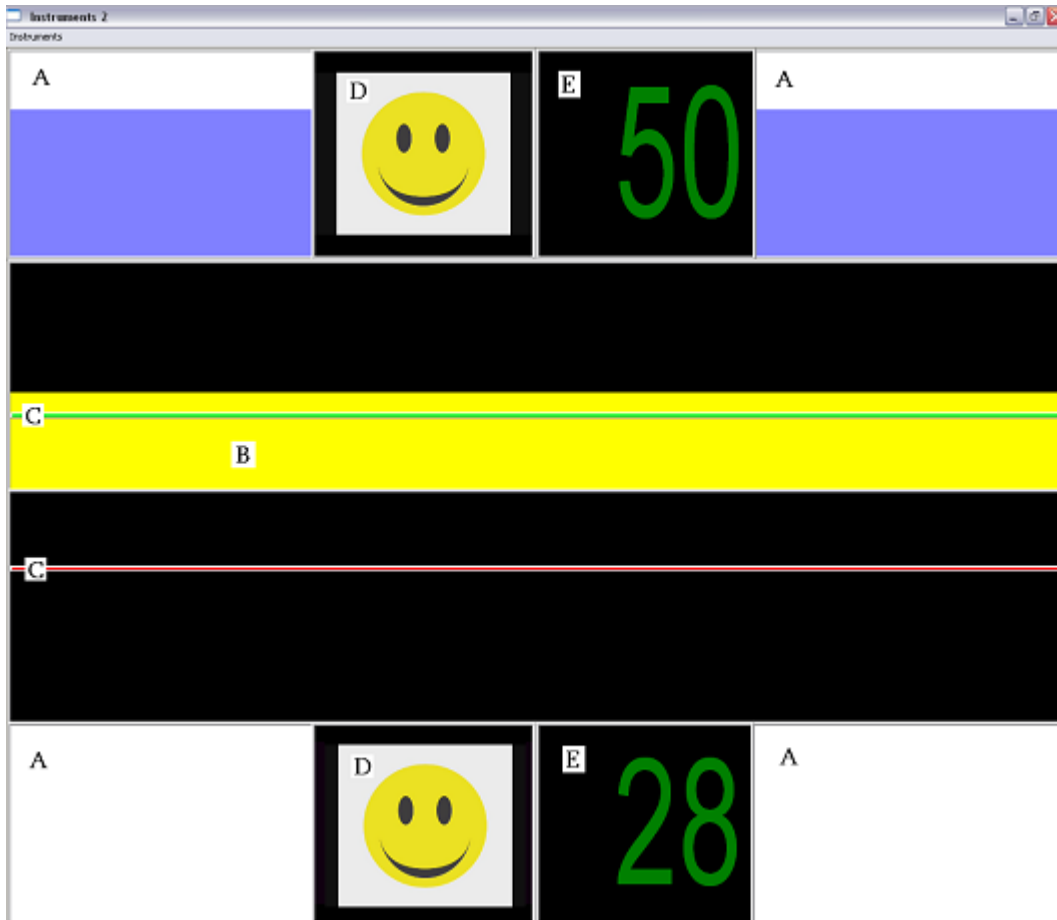

Figure 2. Screenshot of the feedback window in a U trial. A. trial type indicators; B. feedback bar; C. thresholds; D. smiley faces; E. percentages of successful U (top) and D (bottom) trials. Features in top half of the window are associated with U trials; features in the bottom half of the window are related to D trials. Exceptions are the feedback bar – which is either at the top or bottom half of the window dependent of the polarity of the signal relative to baseline; and the reinforcing smileys – which are always shown at both the top and bottom.

‘down’ (D) condition (which required lowering the level of cortical arousal: SCP positivity/SMR enhancement) comprising 60 % of all trials and the ‘up’ (U) condition (heightening arousal: SCP negativity/SMR suppression) comprising 40 % of all trials. The asymmetric distribution was introduced, because previous work by Hinterberger and colleagues (personal communication) indicated that increasing cortical arousal was easier to learn compared to decreasing cortical arousal. Furthermore, since reduction of epileptic seizure is mediated by lowering the cortical excitability level, emphasizing the D condition was hypothesized to be safer and more relevant for epilepsy patients. Participants were seated behind a 17” TFT monitor displaying the feedback window (fig.2) wearing headphones. In a trial the participant had to either increase or decrease

his SCP or SMR. Figure 3 shows the time course of a SCP in a D trial and the feedback window as the participant would see it at different time points throughout the trial. The start of a trial was indicated by a brief tone delivered through the headphones. The trials were divided in a preparation phase and a feedback phase. In the preparation phase, the trial type was indicated to the participant by blinking blue rectangles in either the upper

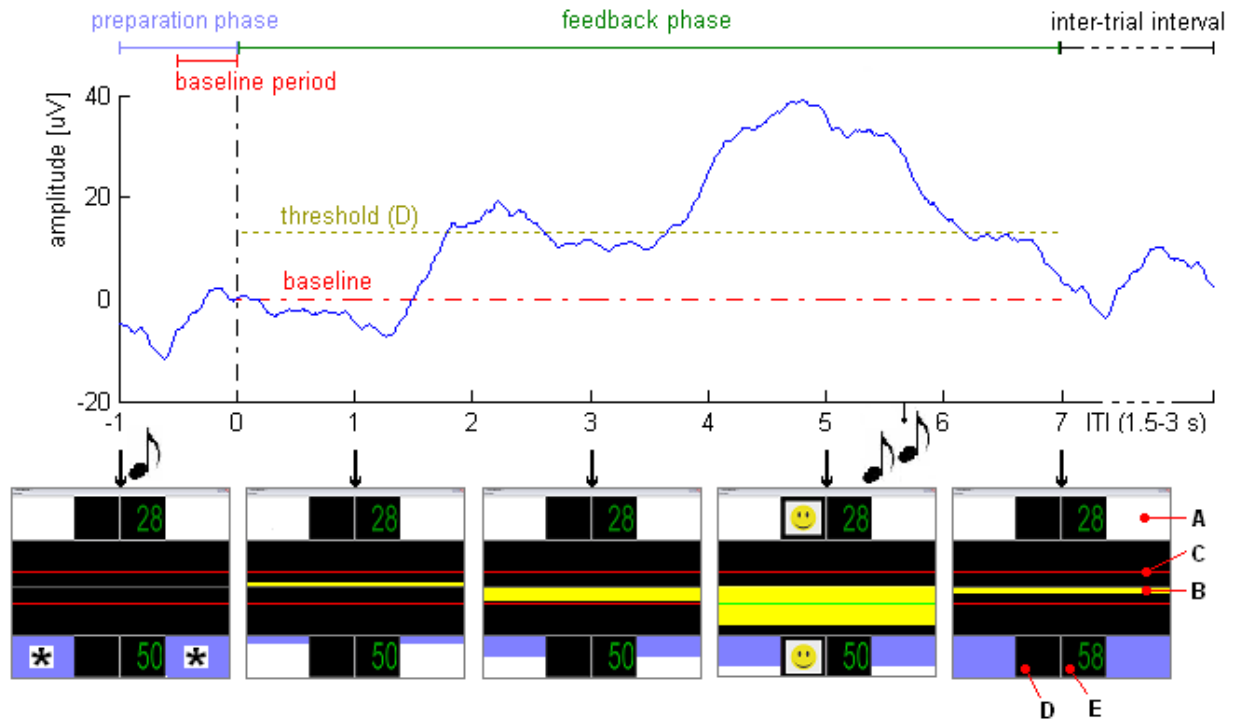

Figure 3. The time course of a SCP signal with the appearance of the feedback window during a D trial. Refer to figure 2 for elements (A-E) of the feedback window. The trace depicts a SCP in a D trial. Every trial was divided in a trial type indication phase ($t = -1-0$ s, preparation phase) and a feedback phase ($t = 0-7$ s). The inter-trial-interval (ITI) was randomly varied between 1.5-3 s. In the 1 second preparation phase the trial type was indicated in the feedback window by blinking blue rectangles (see *). In the feedback phase the participants had to shift their SCP/SMR level from baseline above a threshold level to receive rewards. The baseline (red dashed-dotted line) is the average EEG level of the last 500 ms of the preparation phase (equal to the SCP level at $t = 0$ s, since the SCP is a 500 ms moving average of the EEG). The threshold level is an offset to the baseline that is individually different (ochre dashed line). At $t = -1$ s a brief tone indicated trial start. From $t = -1$ s to $t = 0$ s either the upper or lower trial type indicators blinked (feedback window $t = -1$ s). The SCP level at $t = 0$ s was taken as the baseline level (horizontal midline of the feedback window). From $t = 0$ s to $t = 7$ s feedback is provided on the signal level by the height of the yellow feedback bar. In this phase, the trial type indicators show the amount of time left in the trial. The time left is proportional to the degree to which the indicators are colored. If the signal exceeds the threshold level two reinforcing smiley faces are shown (feedback window at $t = 5$ s). If the signal is above threshold for 2 seconds (SCP) or 0.5 seconds (SMR) consecutively the trial is regarded successful and a reinforcing sound is played. In the example time course the success criterion is reached at $t = 5.7$ s. At $t = 7$ s the success percentages are updated. Since in this D trial the success criterion was reached the percentage of successful D trials is increased from 50% to 58% (note the change in the bottom number from $t = 5$ s to $t = 7$ s).

(U trial) or lower half (D trial) of the feedback window. The mean EEG level in the last 500 ms of the preparation phase served as the baseline for the feedback phase. In the feedback phase, real-time feedback was provided by displaying a yellow bar the height of which was proportional to the level of the feedback parameter (SCP or SMR amplitude) relative to the 500 ms pre-feedback baseline. The pre-feedback baseline level was set at the vertical midline of the window. The visible range of the bar was set such that it was proportional (3x) to the – individually different – threshold values, resulting in an identical visual display for all participants. Negative SCP's and SMR decreases were scaled to be displayed in the upper half of the window and positive SCP shifts/SMR increases were displayed in the lower half, since it is more intuitive to display an increase in arousal as an upward movement of the feedback bar. In the feedback phase, the amount of time that was left to perform the task was indicated in the rectangles that indicated trial type in the preparation phase. In the inter-trial-interval and the preparation phase no feedback was provided. The task requirement was to reach an individually determined threshold level of the feedback parameter relative to the 500 ms pre-feedback baseline and to hold this level for at least 2 seconds for SCP (Hinterberger, personal communication) or 0.5 seconds for SMR (Sterman, personal communication). Reinforcing feedback in the form of two 'smiley' faces was given when the participants reached the – appropriate – threshold. When the task was completed successfully, the participant heard a reinforcing sound, delivered through the headphones. Additionally, feedback on performance was given continuously by displaying the percentage of successful trials in a run for U and D trials separately. These percentages were updated after every trial.

Data processing

A schematic overview of the core of the real-time data processing (noise check, artefact rejection and EOG correction) is provided in figure 4. For the SCP-trained group, the EEG and EOG were smoothed using a moving average of 500 ms and the pre-feedback baseline was subtracted.

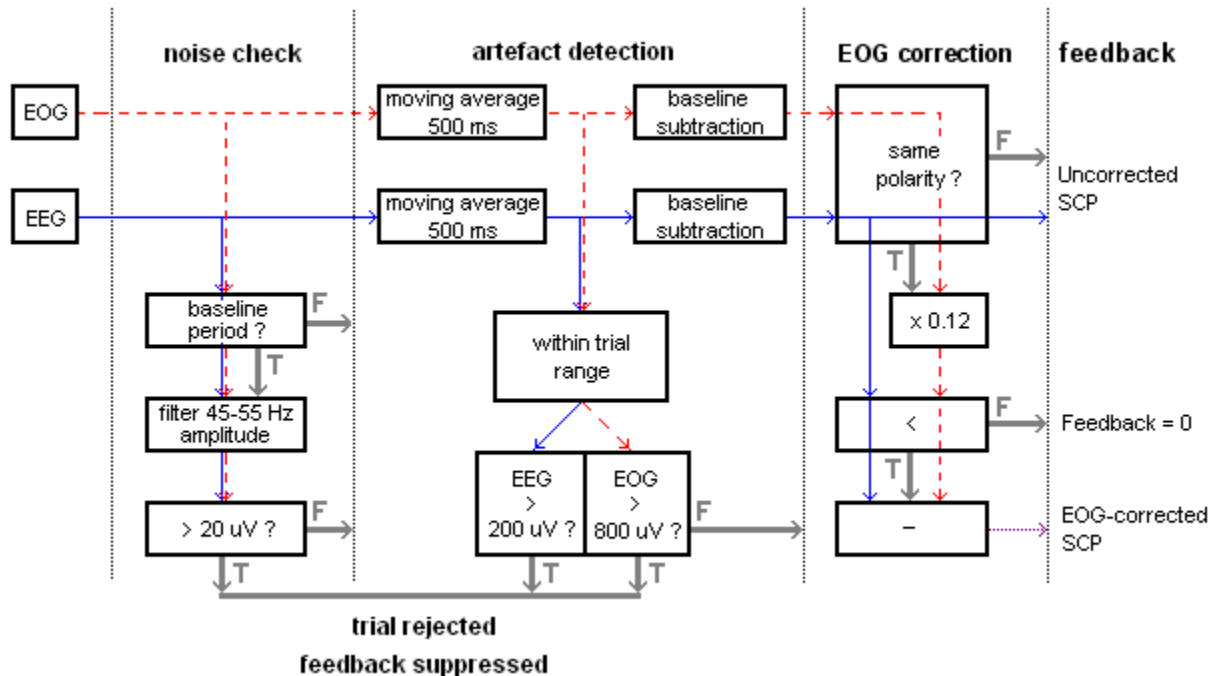

Figure 4. Diagram of real-time SCP data processing. A noise check is performed – in the baseline period only – on EEG and EOG by imposing a threshold of 20 μV on the amplitudes of 45-55 Hz filter outputs (reflecting bad electrode contact or high impedance). Raw EEG and EOG are smoothed by a 500 ms moving average. The EEG and EOG ranges in the trial are determined and compared to the threshold values of 200 μV for EEG and 800 μV for EOG, indicating artefacts due to head movements, touching of electrodes or wires, etc. On a positive outcome of either the noise or artefact check the feedback bar would disappear for the remainder of the trial and the trial was excluded from analysis and success percentages calculation. If EEG and EOG are both within range an EOG correction is performed on the SCP. If the SCP has different polarity as the EOG the SCP is fed back uncorrected, since the EOG contribution will only infer with the task. If the SCP has the same polarity as the EOG and $\text{SCP} < 0.12 \times \text{EOG}$, the feedback will be set to zero to avoid over-correction. If the SCP and EOG have the same polarity and $\text{SCP} \geq 0.12 \times \text{EOG}$, the SCP will be corrected to $\text{SCP} - 0.12 \times \text{EOG}$ and then be fed back to the participants. SMR data processing did not include EOG correction, but featured both the noise check and artefact detection identical to the SCP data processing. Feedback consisted of a 500 ms moving average of the amplitude output of the 12-15 Hz bandpass filtered EEG.

To prevent control of the feedback bar by eye-movement activity, the SCP was corrected in real-time by a method similar to that used by Kotchoubey et al. (1996). If the EEG and EOG were of opposite polarity no correction was performed, since the EOG could not contribute to the task. In case the EEG and EOG were of the same polarity, the EEG was corrected by subtracting the expected EOG contribution at Cz. The multiplication factor for the EOG was set at 0.12 for Cz (Hinterberger, personal communication). To avoid over-correction, the SCP feedback was set to zero if the EEG was smaller than the expected EOG contribution at Cz. Thus, the corrected EEG is calculated by:

$$\begin{aligned}
 EEG_{corrected} &= EEG && \text{if EEG \& EOG have different polarity} \\
 EEG_{corrected} &= EEG - 0.12 * EOG && \text{if EEG \& EOG have same polarity \& } EEG \geq 0.12 * EOG \\
 EEG_{corrected} &= 0 && \text{if EEG \& EOG have same polarity \& } EEG < 0.12 * EOG
 \end{aligned}$$

Feedback was suppressed for the remainder of the trial when:

- the amplitude of the output of a 45-55 Hz bandpass filter of EEG or EOG exceeded the threshold of 20 μ V in the baseline period, reflecting bad electrode contact or high impedance;
- artefacts occurred in the EEG or EOG due to head movements, touching of electrodes or wires, etc. These artefacts become evident as peaks in the EEG and EOG. Thresholds for within-trial ranges were set at 200 μ V for the EEG and 800 μ V for the EOG.

On the occurrence of an artefact the feedback bar would disappear for the remainder of the trial and the trial was excluded from analysis and success percentages calculation. For the SMR-trained group, the SMR amplitude was smoothed by a 500 ms moving average. Then, the 500 ms pre-feedback baseline SMR amplitude was subtracted from the signal. Feedback was provided in the feedback interval only. The artefact criteria for feedback suppression and exclusion from analysis were identical to those in the SCP condition.

Data analysis

Threshold procedure

Each participant was provided with individually determined threshold settings for the ‘down’ (D) and ‘up’ (U) conditions that would start them at 33 % successful trials (the chance level that was chosen). In this way we standardized the procedure by establishing personal thresholds. These personal thresholds were determined based on two pre-training sessions. In the first pre-training session, thresholds were set to a prefixed value (-10 μ V and 10 μ V for the SCP group; -4 μ V and 4 μ V for the SMR group). Every run in a session is associated with a percentage of successful trials, which is dependent on the threshold value. The BioExplorer software package features a ‘playback’ function: the

possibility to re-run the session data, with (the same or) different parameters for data-processing. Employing this function, we can simulate what would have been the success percentages of a run in case different threshold settings would have been used.

The ‘playback’ function was used to determine success percentages for D and U trials with five different threshold settings ($\pm 4, 6, 8, 10, 12 \mu\text{V}$ for the SCP group; $\pm 2,3,4,5,6 \mu\text{V}$ for the SMR group), thus re-running the session 5 times for each of the pre-training sessions with different threshold settings. The resulting success percentages were averaged over the runs of the first pre-training session yielding an average success percentage for each of the threshold settings. Then, a linear regression was carried out on the averages for D trials and U trials separately (see figure 5 for an example). The thresholds for the second pre-training session were taken as the level of the feedback parameter with which 33 % of trials would be successful according to the linear regression of the first session.

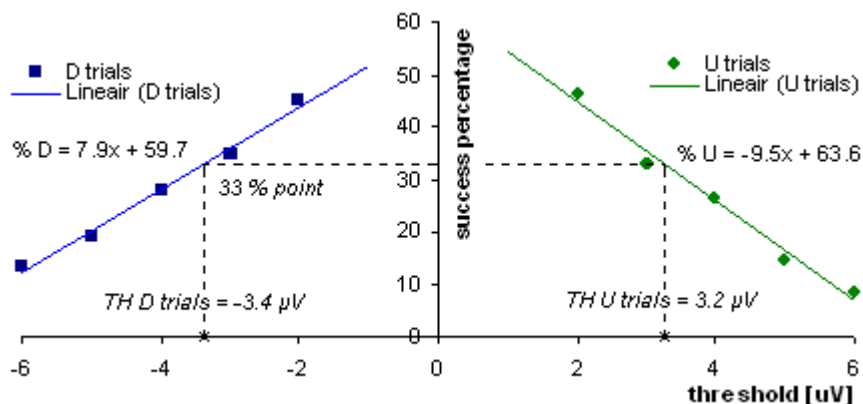

Figure 5. Example of individual threshold determination by linear regression. Data points represent the average pre-training success percentages of SMR-trained participant AB according to offline extraction at different threshold settings ($\pm 2,3,4,5,6 \mu\text{V}$).

The playback procedure was repeated for the four runs of the second session, resulting in another four success percentages for each threshold setting, thus a total of 8 success percentages was obtained from the two pre-training sessions for each of the threshold settings. The success percentages of the pre-training sessions were averaged over the 8 runs, arriving at an average pre-training success percentage for each threshold setting. Again, a linear regression was conducted, now on the average pre-training success percentages. The thresholds for the training sessions were fixed at the level that predicted 33 % successful trials.

Physiological responses

The physiological data (EEG and EOG) were processed using BioReview, Matlab and SPSS software. Invalid trials were excluded from analysis. An entire run was excluded when more than 10 trials were invalid and an entire session was discarded if more than two runs were excluded. The raw signals were filtered offline with the same filter specifications as in the real-time implementation, i.e. the EEG, EOG and 12-15 Hz SMR amplitude were smoothed using a 500 ms moving average. The EEG was corrected for eye-movement influences offline according to the procedure of Gratton et al. (1983). The 500 ms pre-feedback baseline was subtracted from every trial for SMR and corrected SCP. Grand-average SCP and SMR amplitudes were obtained by averaging D and U trials separately in five blocks of four sessions. To quantify physiological responses, the integral between the grand averages of the D/U trials and the baseline was calculated for the feedback phase. Integrals P_D and P_U of the D and U trials, respectively, are defined as:

$$P_D = \int_a^b GA_D dt \qquad P_U = \int_a^b GA_U dt$$

where GA_D and GA_U are the grand-averages of the D and U trials, respectively. These performance measures are calculated for both SCP and SMR in the interval $t = [a,b] = [0,7]$ s. Repeated measures ANOVA's (2x5x2, group x block x trial-type) were performed on the integrals P_D and P_U for both the SCP and SMR response. The significance level was set at $\alpha = 0.05$.

Performance

The participants' performances were analyzed with SPSS software. Runs or sessions were excluded from this analysis if they were excluded in the analysis of the physiological data (≥ 10 invalid trials/run; ≥ 2 rejected runs/session). The percentages of successful trials (for every run) were averaged in five blocks of four sessions. The averaged success percentages were entered in a 2x5x2 (group x block x trial-type) repeated measures ANOVA. The significance level was set at $\alpha = 0.05$.

Results

The efforts to develop a multi-purpose discretized biofeedback system that should be applicable as BCI-system and discrete-trial neurofeedback platform for end-users without experience in physiological measurements resulted in a system for feedback of a single channel of various physiological parameters (EEG, EOG, GSR, HRV, HEG, etc.). It features wireless portable equipment for measurement of the physiological parameters that can be applied by users without experience in physiological measurements. It was designed on the basis of discrete feedback trials consisting of a preparation phase and a feedback phase. It uses combined visual and auditory cues, visual feedback of only a single channel of the physiological parameter and a two-stage combined visual and auditory reinforcement. Additionally, it features automated online correction for EOG. Finally, it incorporates a method for the derivation of individual threshold settings that are the criterion for reinforcement. A series of trainings was performed to address a number of questions regarding the performance of a group of nineteen participants using the new biofeedback system. All nineteen participants completed the training.

Physiological responses: group results

Figure 6 shows the grand-average SCP's for D (solid traces) and U (dashed traces) trials of the five blocks. In the preparation phase, a negative potential builds up (readiness potential). At the start of the feedback phase a positive potential shift is seen. Over the feedback phase the potential slopes towards positivity. In the preparation phase, the SCP-trained participants show an increasingly negative potential over blocks in the D trials. This is accompanied by a larger positive shift at the start of the feedback phase. Additionally, the positive slope during the feedback phase appears to be larger in the third and fourth block, as compared to the first and second block. This suggests that the SCP-trained participants have the ability to increase the difference between baseline potential and feedback phase potential over the course of the experiment. In the U trials, the SCP-trained participants show a decreased negative potential in the preparation phase compared to the D trials. Furthermore, the SCP-trained participants are able to suppress the positive potential shift that is seen at the start of the feedback phase in the D trials. As a result, we see that the differentiation between the D and U trials is

generally larger in the later blocks of the experiment. For the SMR-trained group, the negative preparation phase potential is equal for both trial types and a positive potential shift is seen at the start of the feedback phase. In the remainder of the feedback phase the potential slopes towards positivity in both D and U trials. However, the grand-average SCP response of the D trials shows a steeper slope as compared to the grand-average SCP of the U trials, thus resulting in a differentiation in the SCP response between D and U trials. It can also be noted that the negative preparation phase potential increases over blocks. This shifts the potential in the feedback phase towards positivity, relative to the baseline. However, there is no indication that the differentiation between D and U trials increases over blocks.

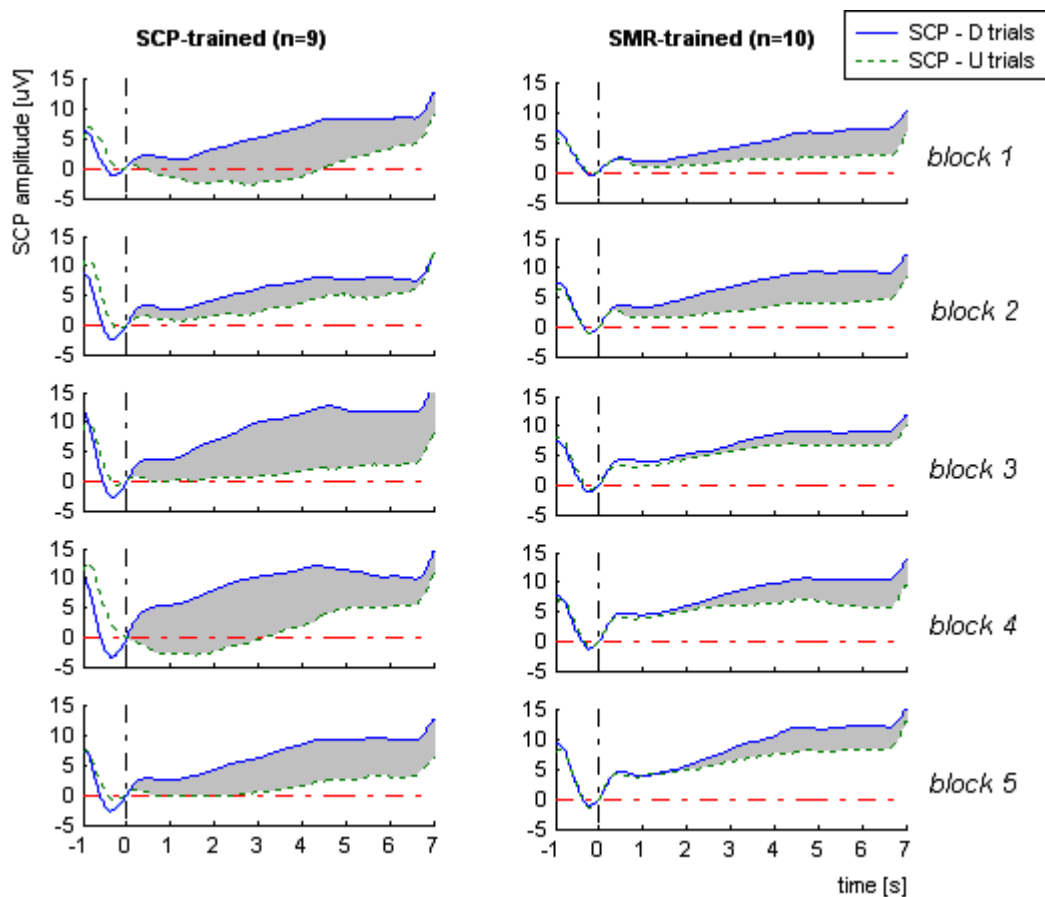

Figure 6. Grand-average SCP's for the five blocks of four sessions of the SCP-trained group (left column) and the SMR-trained group (right column). Solid lines represent the average SCP response to D trials and dashed lines represent the average SCP response to U trials. The baseline is represented by the horizontal dashed-dotted line and the start of the feedback phase is indicated by the vertical dashed-dotted line at $t = 0$ s. The differentiation between D trials and U trials is indicated by the shaded area.

The grand-averages of the SMR amplitude are shown in figure 7. Both the SMR-trained and SCP-trained groups show a burst of SMR activity in the preparation phase. The SMR-trained group shows a mildly suppressed SMR response in the feedback phase in the first blocks of the experiment that is not seen in the SCP-trained subjects. Most importantly, no differentiation between D and U trials is observed in the feedback phase for the the SMR-trained group, nor for the SCP-trained group.

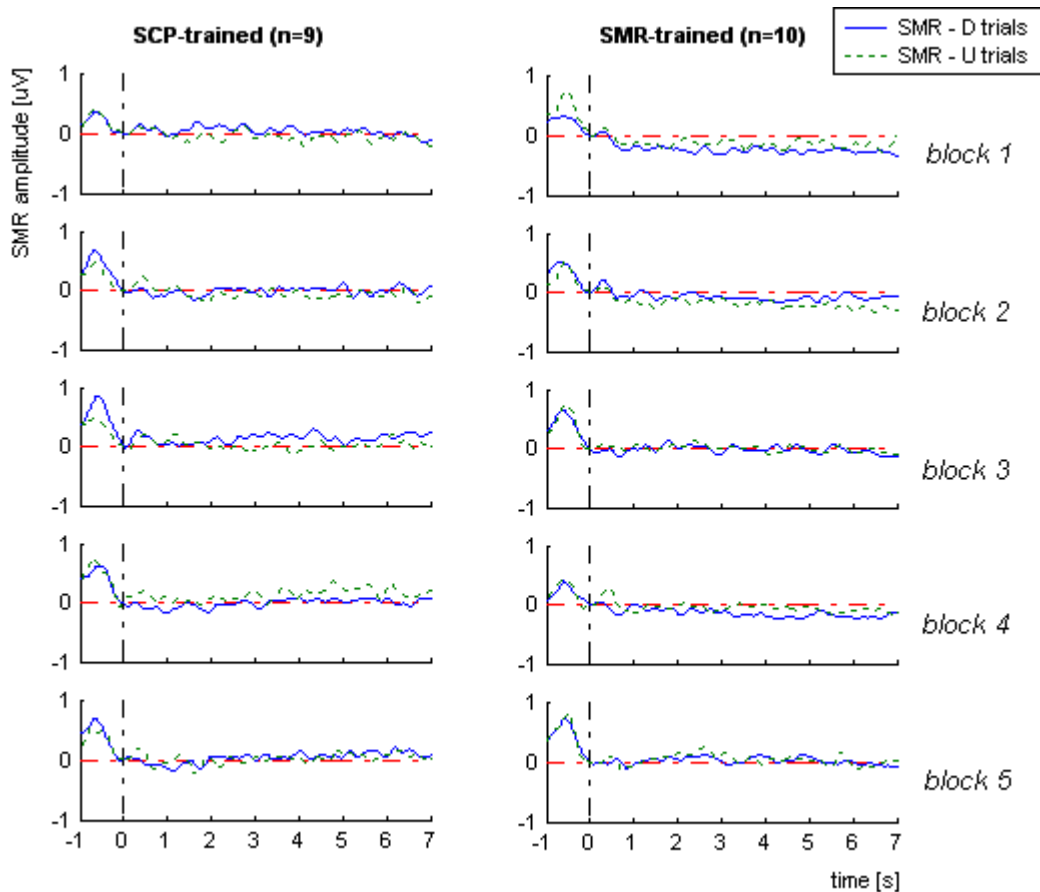

Figure 7. Grand-average SMR amplitudes for the five blocks of the SCP-trained (left column) and the SMR-trained group (right column). Solid lines represent the average SMR response to D trials and dashed lines represent the average SMR response to U trials. The baseline and start of the feedback phase are indicated by the horizontal and vertical dashed-dotted line, respectively.

The ability to regulate the SCP and SMR across session blocks was quantified by calculating the integrals P_D and P_U between the baseline and the grand-averages for the feedback phase of the various blocks in the experiment for both the SCP-trained group and the SMR-trained group. The group results for P_D and P_U are summarized in figure 8.

Figure 8 shows the group-averaged P_D and P_U of the SCP-trained group (diamonds, solid lines) and the SMR-trained group (squares, dashed lines) for the SCP response (left panel) and the SMR response (right panel). Interestingly, the integrals of the SCP response show a differentiation for both the SCP-trained and SMR-trained participants. It can be observed that the SCP differentiation between D trails and U trials of the SCP-trained participants increases over blocks (left panel; growing interior of the solid lines). In contrast, the SCP differentiation of the SMR-trained participants is constant over blocks (left panel; dashed lines are parallel), but shows a nonspecific increasing trend (equal positive slope of the dashed lines). This probably suggests a shifting baseline SCP level in both D and U trials. The integrals of the SMR response are undifferentiated for both the SMR-trained group (right panel; dashed lines) and SCP-trained group (right panel; solid lines). In the SMR-trained group, both P_D and P_U show the same trend towards positivity, i.e. from a suppression of SMR in the first block to the absence of a SMR response in the last block.

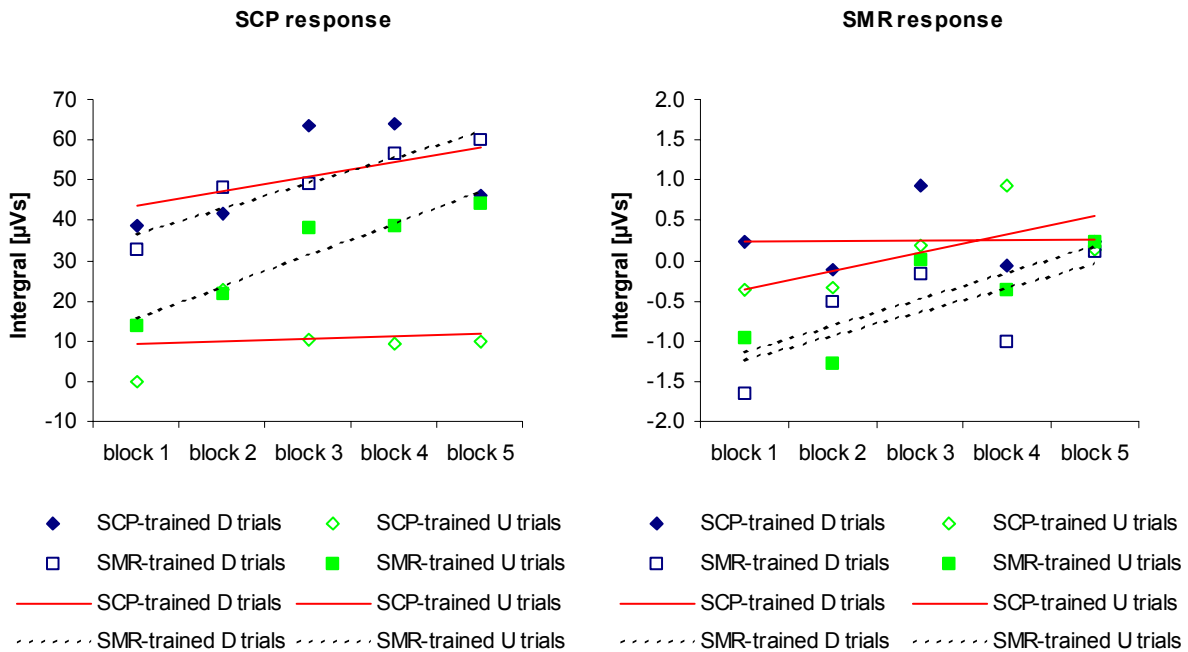

Figure 8. Integrals P_U and P_D between the baseline and the grand-average SCP (left panel) and SMR (right panel) for the SCP-trained (diamonds; solid lines) and SMR-trained group (squares; dashed lines). Note the increased SCP differentiation of the SCP-trained group over blocks (solid lines in the left panel); the SCP differentiation of the SMR-trained group which is stable over blocks (dashed lines in the left panel); the undifferentiated SMR response in the SMR-trained group (dashed lines in the right panel) and the absence of a clear SMR effect in the SCP-trained group (solid lines in the right panel).

The integrals P_U and P_D of both the SCP response and SMR response were entered in a $2 \times 5 \times 2$ (group \times block \times trial type) repeated measures ANOVA. For the SCP response, a significant effect of trial type was found ($F(1,17) = 20.050$, $p < 0.000$). This indicates that participants differentiated in their response to U and D trials. It could not be shown that this differentiation was larger for the SCP-trained group as compared to the SMR-trained group (non-significant trial type*group interaction, ($F(1,17) = 2.984$, $p = 0.102$)). Furthermore, a significant main effect of block was found ($F(4,14) = 4.666$, $p = 0.013$). Post-hoc contrasts indicated a significant increasing quadratic trend in the data ($F(1,17) = 12.246$, $p = 0.003$). This suggests a more positive general SCP level relative to baseline over the blocks, which was the same in the SCP-trained group and the SMR-trained group (non-significant block*group interaction ($F(4,14) = 1.007$, $p = 0.437$)). The three-way interaction trial type*block*group was also significant ($F(4,14) = 3.708$, $p = 0.029$). Post-hoc contrasts revealed that this interaction occurred in block 2, where the SCP differentiation in the SCP-trained group is reduced compared to the other blocks and the SCP differentiation in the SMR-trained group is increased compared to the other blocks. Therefore, the three-way interaction did not provide compelling evidence for the hypothesis that the SCP differentiation shows a larger increase over blocks in the SCP-trained participants compared to the SMR-trained participants. The ANOVA on the SMR response yielded no significant effects. This result indicates that, in the group average, the SMR response in the feedback phase did not deviate from the pre-trial baseline in either the SMR-trained or SCP-trained participants and that no progress was made across blocks.

Physiological responses: responders

Analysis of the data of the individual participants indicates that the variability between the participants was large. The SCP-trained participants ($n=9$) can be divided in two relatively homogeneous groups based on their ability to control their SCP (the criterion was a larger slope of a least-squares linear regression for P_D as compared to P_U over blocks, see also figure 8 for the group example). First, there is a group of four participants who were able to increase the differentiation between their SCP responses on D and U trials over the blocks (responders, figure 9). The increase in differentiation was primarily caused by SCP increases in the D trials (four participants). One participant

was able to also progressively decrease her SCP in the U trials over the blocks. Second, five participants showed essentially the same response in all sessions or even a decrease in differentiation (1 participant).

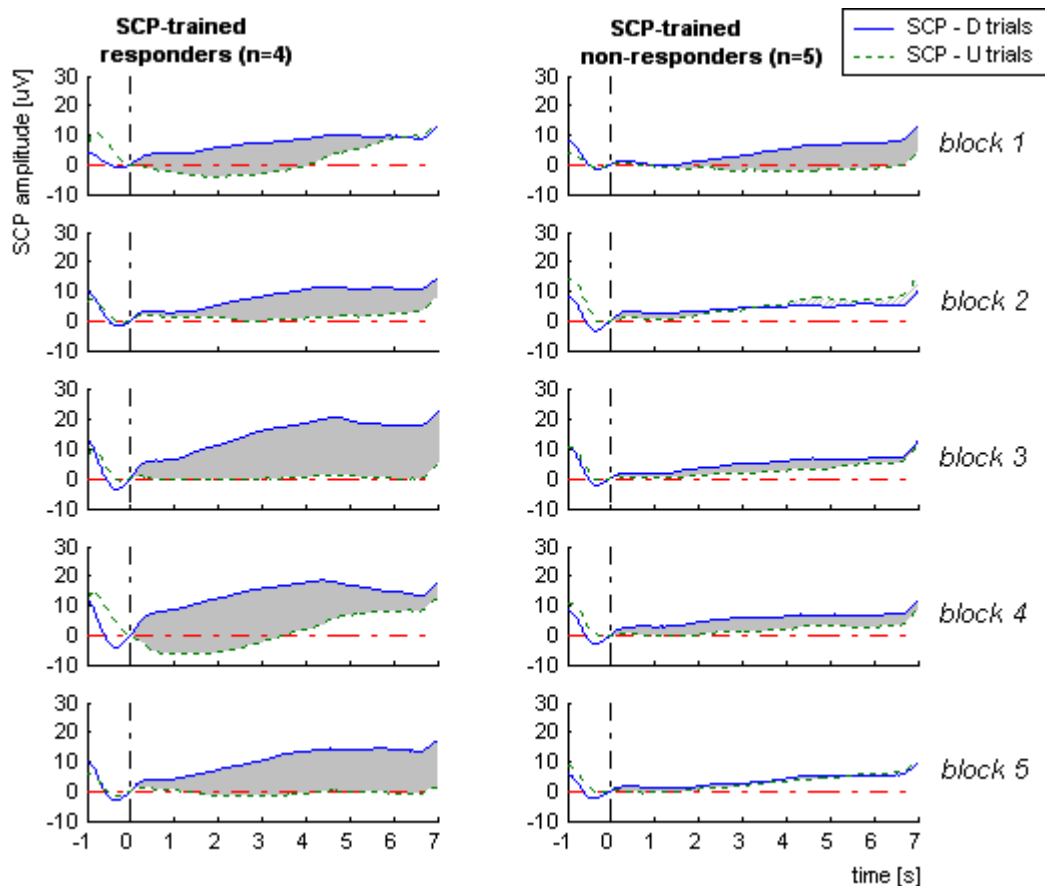

Figure 9. Grand-average SCP's for the five blocks of the SCP-trained responders (left column) and the SCP-trained non-responders (right column). Solid lines represent the average SCP response to D trials and dashed lines represent the average SCP response to U trials. The baseline and start of the feedback phase are indicated by the horizontal and vertical dashed-dotted line, respectively. The differentiation between D trials and U trials is indicated by the shaded area. The hatched area represents a negative contribution to the differentiation.

In the group of the SMR-trained participants (n=10) the number of responders (n=6) was higher than in the SCP-trained group. Three out of ten participants were able to progressively decrease their SMR in the U trials (U trial responders) and four participants showed consistent increases in SMR amplitude in the D trials over the blocks (D trail responders). In general, these participants were not able to *differentiate*

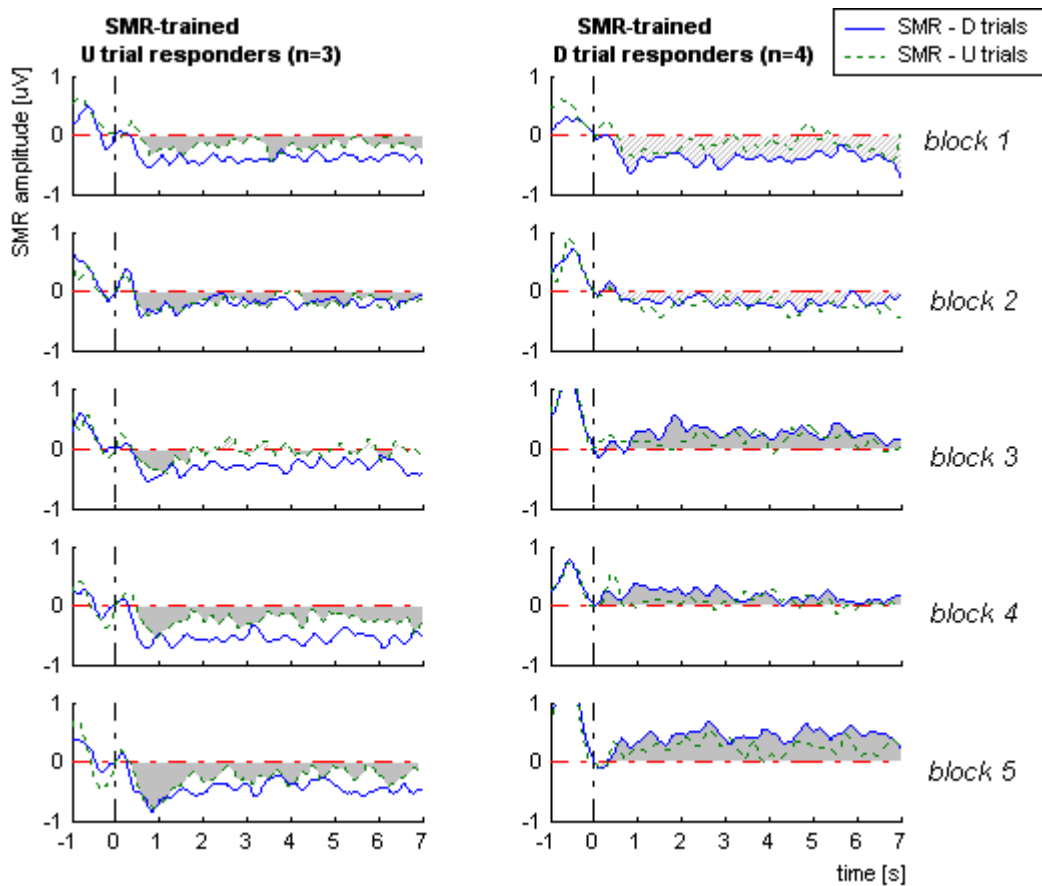

Figure 10. Grand-average SMR amplitudes for the five blocks of the SMR-trained U trial responders (left column) and the SMR-trained D trial responders (right column). Solid lines represent the average SMR amplitude response to D trials and dashed lines represent the average SMR amplitude response to U trials. The baseline and start of the feedback phase are indicated by the horizontal and vertical dashed-dotted line, respectively. Shaded areas accentuate the relevant required response; hatched areas indicate an inappropriate response.

their response between D and U trials (figure 10). One exception was a participant who was able to both decrease the SMR in U trials and increase the SMR in D trials over blocks. From figure 10, it seems that the general response of the SMR-trained responders to both U and D trials is a suppression of SMR in the feedback phase compared to the pre-feedback baseline (see also figure 7). Further, figure 10 shows that, in the first two seconds of the feedback phase, the U trial responders (left column) exhibit an increasingly suppressed SMR response in the U trials (dashed trace) over blocks. However, roughly the same trend is seen in the D trial (solid trace), where this response is inappropriate. Moreover, the SMR in the D trials is even more suppressed

compared to baseline than it is in the U trials. An opposite – but similar – pattern is seen for the D trial responders (right column). These participants also showed a suppression of SMR compared to baseline in the first block in both trial types, but gradually changed their response in the feedback phase to an SMR enhancement. Again, they showed this in the D trials (the required response) as well as in the U trials (the inappropriate response).

Performance

The performance of the participants was evaluated separately. The task for the participants was to increase the percentage of successful trials. The criterion for a successful trial was to exceed a personalized threshold level of the trained parameter for 2 seconds (SCP) or 0.5 seconds (SMR). The success percentage of a run was fed back continuously to the participants and updated after every trial. The mean success percentages of the five blocks are shown in figure 11 for the D and U trials of the SCP-trained and SMR-trained groups separately. Although three of the four graphs show an increasing trend over experimental blocks, the percentual increase is modest. Nevertheless, a number of participants did manage to increase their success percentage considerably, in one or both trial types. To illustrate this, the best performers in both trial types of both groups are included in the plots of figure 11. In the SCP-trained group four participants increased by more than 2.5 % per block on D trials. On the U trials, there were three SCP-trained participants with an increase rate larger than 1.5 % per block with one participant achieving even an increase in success percentage of more than 8.5 % per block. For the SMR-participants, two participants achieved an increase of more than 2.5 % per block on D trails and two participants increased more than 1.5 % per block on U trials.

To investigate if the participants were able to increase their success percentage a 2x5x2 (group x block x trial type) repeated measures ANOVA was performed on the success percentages. In spite of a large number of participants showing the correct average physiological responses it cannot be concluded from the results of this analysis that the two groups of participants were able to increase their success percentage, since the ANOVA did not demonstrate any significant effects.

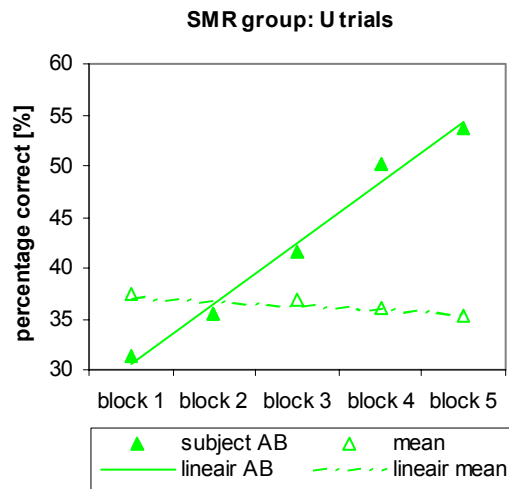
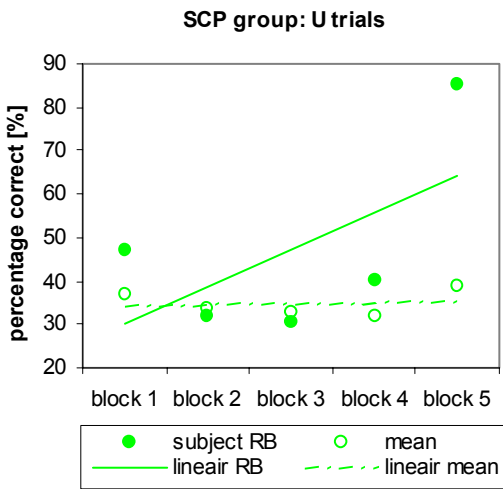
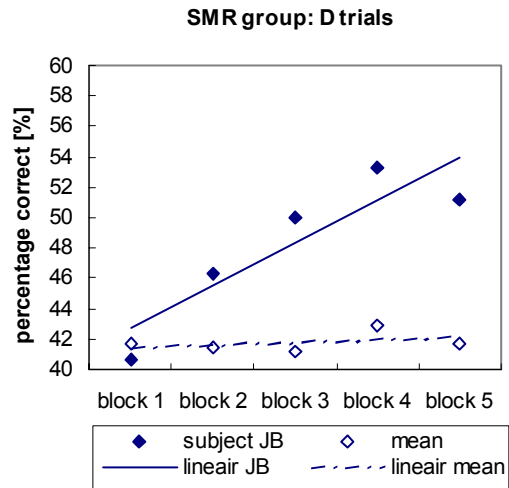
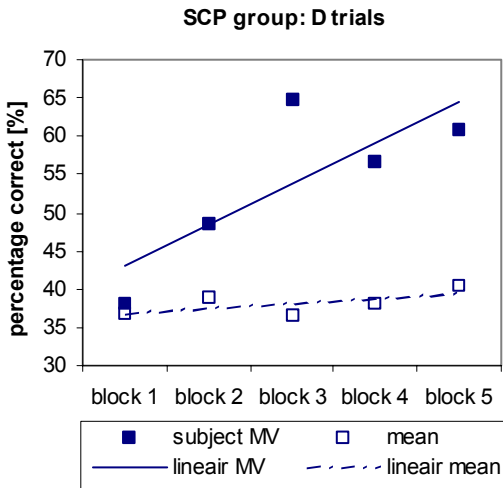

Figure 11. Success percentages for the mean across subjects (open points) and best-performing subject (filled points). The dashed lines represent the least-squares linear fits of the mean success percentages and the solid lines represent the least-squares linear fits of the success percentages of the best-performing subjects.

Discussion

To accommodate the need for practical BCI-systems, a new biofeedback system was developed that uses portable wireless equipment to measure physiological variables (EEG, EOG, GSR, HRV, HEG, etc.). The system is easy to self-apply and features software that can be operated with only a limited amount of training. Using this system, we tested a novel approach for single electrode SMR and SCP training on the basis of discrete feedback trials employing automated online correction for EOG and a method for the derivation of personalized threshold settings. This approach was tested in an experiment that aimed to teach nineteen participants to self-regulate their SCP or SMR amplitude. More than half of the participants (10/19) were able to acquire some control over their SCP or SMR response, with the results showing distinctive inter-individual differences, where SCP responders (n=4) were mainly successful in SCP positivity trials and SMR responders were successful in either SMR uptraining (n=4) or SMR downtraining (n=3) and one participant was able to master both conditions.

Physiological responses

Our results indicate that not all participants are able to gain control over their slow cortical potentials. This is in line with previous studies. In a study on healthy subjects by Rockstroh et al. (1990), less than half (21 out of 45) of the subjects mastered the skill of SCP self-regulation. This is very comparable to the results we observed in this study (4 out of 9 subjects). Hinterberger et al. (2004) reported successful regulation in six, four and two subjects in three groups of 18 subjects receiving visual, auditory and combined feedback, respectively. Comparable results have been obtained by Mohr et al. (1998) who were successful in teaching six of their twelve subjects to regulate their hemispheric SCP asymmetry. In contrast to our study, these studies used full-cap EEG systems for training their participants. The variability in the success of self-regulation of the SCP is also observed in epilepsy patients (Rockstroh et al., 1993; Kotchoubey et al., 1996; Strehl et al., 2006) and ALS patients (Neumann and Birbaumer, 2003).

A decrease in SCP differentiation of the SCP-trained responders was observed in the last blocks of the experiment. This may have been due to a number of reasons. First, the acquisition of the skill of self-regulation is motivationally dependent (Kleinman, 1981).

Oral reports from the participants in the present experiment indicated a decrease in motivation throughout the second half of the experiment. The relatively large extent (8 weeks) of our study may have been a factor that influenced the motivation of the participants negatively. Clearly, healthy participants have little to gain from self-regulation of their SCP or SMR. This is in contrast to epilepsy patients, who are possibly able to reduce their seizures through self-regulation. For future research, a performance dependent monetary reward, as was reported by Elbert et al. (1980), might boost the participants motivation to obtain a maximum increase in their performance. Another possibility to boost motivation is to couple the participants to introduce a competitive element in the experiment. Parente & Parente (2006) found that the coupling of participants led to a significantly better performance as compared to a non-competitive approach. Another possible solution is to adjust the salience of the reinforcer. Because reinforcement contingent on the desired response is the most important principle in biofeedback (Kleinman, 1981; Siniatchkin et al., 2000; Sterman & Egner, 2006), it might be worthwhile to investigate the effects of the introduction of novel reinforcers within or across the sessions.

One of the questions that is addressed with the present experiment concerns whether SCP or SMR training has the most potential for BCI and epilepsy treatment. In total only four out of nine SCP-trained participants were successful while in the SMR-trained group, six out of ten participants responded to the training procedure. On both D and U trials, a number of SMR-trained participants showed the required responses. SMR suppression or enhancement could be increased over the course of the training by respectively three and four SMR-trained participants. However, these participants showed the same response to both the D and U trials. Thus, four participants showed an increased SMR in not only D trials, but also in U trials; and three participants showed a decreased SMR in not only U trials, but also in D trials. This inability to differentiate in their responses led to cancellation of the effect in the group-average, which did not deviate from the pre-feedback baseline. This suggests that it is very hard to switch between SMR enhancement and suppression on a very short time-scale.

We are unaware of previous research investigating SMR enhancement and suppression switched on a trial-by-trial basis. Sterman and Shouse (1980) were successful in both enhancing and suppressing SMR in single subjects but not on a trial-by-trial basis. They

switched contingencies after three months of rewarding SMR enhancement to rewarding SMR suppression and did not use discrete trials. Compared to the pre-experiment baseline, they showed a significant increase in 12-15 Hz NREM sleep activity during the SMR enhancement periods, but a non-significant decrease in 12-15 Hz NREM sleep activity during the SMR suppression period. Performance ratios increased significantly in both SMR enhancement and SMR suppression periods, albeit to a much larger degree in the enhancement periods. They reported a range of performance ratios of 1.4 to 6.2 times above chance level in four subjects when rewarding SMR enhancement, but did not report individual performance ratios in SMR suppression periods.

Previous research has mainly focussed on increasing SMR in a continuous task setting. Vernon et al. (2003) trained ten subjects to increase their SMR over Cz in eight sessions comprising five three-minute periods of continuous feedback. They reported an increase in SMR/Theta and SMR/beta ratios in this group of subjects over the five within session periods, but did not report on effects over sessions. Furthermore, no indication concerning the performance of individual subjects was provided. Kropotov et al. (2005) found that in a group of 86 children with ADHD, 71 children were good performers on the task of increasing the relative 15-18 Hz activity on C3 and 12-15 Hz activity on C4 sequentially. However, it was not specified whether the children performed equally on the increase of 15-18 Hz and 12-15 Hz.

Interestingly, in the *SMR-trained* group it was observed that the SMR enhancement trials were associated with larger *SCP positivity* compared to the SMR suppression trials. In contrast, the SCP-trained subjects did not show equivalent changes in SMR response (figure 8). A possible relation between SCP and SMR was also proposed by Kotchoubey et al., 1999. They did not find consistent changes in EEG power spectra in their SCP-trained epilepsy patients, but attributed the observed post-training changes in delta, theta, alpha and beta frequency bands to non-specific changes in the subjects brain state. A similar non-specific effect can be concluded from our data, because we observed a constant SCP differentiation in the SMR-trained responders over the course of the experiment, whereas the SMR response was either increasing (enhancement trial responders) or decreasing (suppression trial responders). In addition, directional differentiation between the enhancement-required and suppression-required trials was achieved for SCP but not for SMR. We suggest that the differentiation in the SCP

response while training *SMR* is caused by modulation of central arousal mechanisms that are, in turn, modulated by the *SMR* training. Equivalent changes do not occur in the *SMR* while training *SCP*, because *SCP* training induces local effects and does not modulate central arousal.

In theory it is possible that the *SCP* differentiation in the *SMR*-trained participants originates from a source outside the brain (EMG/EOG contamination). However, EMG contamination is unlikely since it can be expected that the *SMR* response would be highly effected by EMG artefacts. Because we observed a very similar *SCP* response (that was constant over blocks) in the enhancement trial responders and the suppression trial responders of the *SMR*-trained group while the *SMR* response of these groups developed in directions opposite to each other, we can exclude the involvement of EMG. It is also possible that the EOG correction procedure is inadequate. However, we find this explanation highly unlikely, because the data from a third group that was trained (on galvanic skin response; *GSR*) using the exact same procedure (data reported elsewhere; Spronk et al., *in preparation*) did not show any *SCP* differentiation. If the design would have caused consisted eye-movements that affected the *SCP* at Cz and, moreover, would not have been corrected by the EOG correction procedure, we should have observed similar *SCP* differentiation in the *SMR*-trained participants and this third group of *GSR*-trained participants.

Performance

Similar to the physiological responses, the ability to improve the success percentage (above the 33 % chance level) over sessions varied considerably across participants in the present experiment. On average, the increase in the percentage of successful trials was only moderate, but individual participants showed considerable improvements in successful responses. Comparable results have been obtained by Neumann and Birbaumer (2003), who investigated correct response rates in a group of five ALS patients that were trained on their slow cortical potentials. This study indicated significant improvement in correct response rates in three patients, with only one patient exhibiting a very high and stable degree of control.

In other BCI research – employing mu and beta rhythms – the correct response rate is generally higher than observed in this experiment. McFarland et al. (2005) reported

accuracies ranging from 80 % to 100 % (with a chance level of 50 %) after 10 sessions in five out of seven subjects, whereas two subjects were unable to achieve control over their mu or beta rhythm. Pfurtscheller and colleagues use a very different approach to BCI. They classify imaginary movements of the users by detecting event-related desynchronization (ERD) or event-related synchronization (ERS). In one of their initial BCI experiments (Pfurtscheller et al., 1997), they report on three subjects that show large differences in EEG rhythms over sensorimotor cortex during left vs. right hand movements that could be classified with an accuracy of 70-90 % (chance level at 50 %). However, seven subjects failed to show sufficient EEG differences.

The methodology that was used in these experiments was very different from our own and this could explain the differences between the correct response rates in their and our experiments. First, the trained EEG frequencies were different. We sought to investigate the possibility of operating a BCI with the 12-15 Hz rhythm, whereas McFarland et al. (2005) and Pfurtscheller et al. (1997) use a strategy of finding the exact frequency of mu or beta oscillation in individual subjects and centering the bandpass filter around that frequency. Nevertheless, in experiments featuring this approach a number of subjects also fails to respond to training, despite being trained on their exact mu or beta frequency. In addition, a relatively large number of participants in other experiments does respond well to the discrete 12-15 Hz training (see also Lantz & Sterman, 1988; Sterman, 1984). Lubar and Lubar (1984), for example, showed improvements in SMR acquisition with extended training in all six children that were included in their report. However, they did not specify the inclusion criteria. The selection of the mu or beta rhythm therefore is not a requirement, nor a guarantee for achieving control but in some cases it can be advantageous. Contrary to SMR-feedback for the purpose of epilepsy treatment – where the therapeutic effects are specific for the 12-15 Hz frequencies – it may be important in BCI to individualize the feedback frequency to accommodate the users with the possibility of achieving maximum control accuracy.

Second, the electrode location for feedback used in this experiment was Cz. Whereas for SCP neurofeedback good results have been obtained with the Cz placement (Birbaumer et al., 1999; Hinterberger et al., 2004; Rockstroh et al., 1993; Kotchoubey et al., 1996), in sensorimotor neurofeedback lateralized electrodes over sensorimotor cortex are considered most suitable (Sterman et al., 1974; Kropotov et al., 2005). This is especially

important in the procedure of Pfurtscheller et al., since the specific instruction of motor imagery of, for example, hand movements calls for the placement of electrodes over the hand areas of the motor cortex. Furthermore, Cz electrode placement can be problematic for measurement of the SMR, because of cancellation of non-phase-locked synchronized rhythmic activity from the left and right sensorimotor cortex on the sagittal midline (Storm van Leeuwen et al. (1978), but see also Egner & Gruzelier (2003) and Pfurtscheller et al. (2006) for examples of SMR/mu rhythm control over Cz). We selected the Cz electrodes for both the SCP-trained group and the SMR-trained group for standardization purposes between the groups, but this could have impeded learning in the SMR-trained participants.

Third, in principle it is possible that our evaluation of success was not optimally suited for learning to increase the success percentage. We adopted a procedure that started the participants at 33 % correct responses in the first experimental session, whereas in the studies mentioned above chance level was at 50 % correct responses. Related to this, the experiment featured an approach that was based on fixed threshold levels based on two pre-training sessions. With this method, the thresholds may have been set too high. Because the participants were highly motivated at the start of the experiment, it is conceivable that learning has already taken place in the pre-training sessions. This would be in accordance with the results of Kotchoubey et al. (1997) and Siniatchkin et al. (2000) who found that healthy participants can learn to control their SCP in as few as two sessions. If the participants indeed learned to increase or decrease their SCP and SMR levels in the pre-training sessions to a near maximal performance, this would certainly have lead to threshold settings that do not leave much room for improvement. For the SCP group, our data supports this hypothesis, because already in the first block of the experiment a large differentiation was found in the SCP response between D and U trials in some subjects. Furthermore, the fixed threshold levels throughout the experiment could have diminished the performance. As was already argued by Skinner (1975), the shaping of the desired response is a very important element in operant conditioning. In neurofeedback, shaping is achieved by progressively adjusting the reward threshold level according to the performance of the participant. This approach therefore takes into account not only the inter-subject variability, as in the approach in the present experiment, but also the inter-session variability of performance. In case

performance stabilizes or even decreases, a stagnation of learning can occur, when no adjustments are made in the difficulty level of the task. Therefore, the inability of some participants to increase their success percentages and low degree of control over their physiological responses could have been due to the absence of a shaping procedure.

Fourth, the time window associated with the response criterion may be an important element. Our approach required the participants to sustain their SCP or SMR amplitude above threshold level for a period of time. The window for sustaining the threshold level was set at 0.5 seconds for the SMR-trained participants. This criterion is very suitable for training epilepsy patients to produce SMR, since they are only rewarded for extended burst of activity. For BCI, however, sustained activity is not necessary, but could serve as a mechanism to reduce false positives. The SCP-trained participants had to hold their SCP above threshold for a period of two seconds to achieve a successful response. In the approach of Rockstroh et al. (1990) and Neumann et al. (2003) the SCP response is averaged over the active phase of the trial (3-5 seconds) and considered correct if the average response is above a threshold level. Presumably, the correct response criterion of holding the SCP/SMR level above threshold for an extended period is more difficult, since only minor shifts in SCP/SMR amplitude can have a large impact on whether the criterion is met. This can possibly explain the difficulty of improving the correct response rate in the present experiment. This can also explain that some participants seemed to improve their correct response rate to a lesser extent than their physiological performance.

Another consideration related to the trial set-up that could have influenced the results negatively is a disfacilitation of the consolidation of learning. In operant conditioning, a rewarded response is followed by a burst of dominant frequency activity called a post-reinforcement synchronization (PRS) that indicates a strengthening of the associations between the response and the reward (Buchwald et al., 1964; Clemente et al., 1964; Pfurtscheller, 1992). The occurrence of this important post-response synchronization may have been disfacilitated in our experiment by not ending a trial immediately after the reward has been delivered. Instead, on reaching the reward criterion the reward was delivered and feedback on the physiological parameter continued for the remainder of the trial. The ongoing feedback after the reward deliverance could have encouraged the participants to – unconsciously – stay focussed on the feedback and thereby hampered

the PRS necessary for consolidation of the response-reward association. Furthermore, the continuation of the trial might have confused the participants in thinking that they had not reached the true goal yet.

Conclusions

With our proposed biofeedback system, 10 out of 19 participants that were trained on their slow cortical potentials or sensorimotor rhythm were able to achieve control over their brain activity. The group of SCP-trained participants showed more improvement in the positivity-required condition as compared to the negativity-required condition. The group of SMR-trained participants performed better on SMR enhancement as compared to SMR suppression. For SMR, most participants did not achieve bidirectional control. The answer to the question which EEG characteristic, SCP or SMR, could be controlled best, is inconclusive. A larger percentage of participants was able to gain unidirectional control over SMR, but the responding SCP-trained participants showed bidirectional differentiation. Our findings indicate that – for BCI research – future studies should acknowledge interindividual differences. For example, by finding whether someone is better in up- or downtraining SCP or SMR one could focus the training only on that aspect rather than focusing on bi-directional control. Our results also stress the need for personalizing training procedures for users in order to achieve reliable responses that can be utilized in BCI's. Interestingly, changes in the passively recorded parameter occurred in the SMR-trained group, but not in the SCP-trained group, i.e. the SMR-trained group showed SCP differentiation, but the SCP-trained group did not show equivalent effects in SMR response. This suggests that SMR training modulates central arousal mechanisms and influences the SCP accordingly, but that SCP training invokes only local effects and does not affect central arousal systems and – consequently – SMR.

Abbreviations

ADD/ADHD	attention deficit disorder / attention hyperactivity deficit disorder
ALS	amyotrophic lateral sclerosis
BCI	brain-computer interface
BRC	Brain Resource Company
D	'down' trial – SCP positivity-required; SMR enhancement-required
EEG	electroencephalogram
EMG	electromyogram
EOG	electro-oculogram
ERD/ERS	event-related desynchronization / event-related synchronization
GSR	galvanic skin response
HEG	hemoencephalography
HRV	heart rate variability
ITI	inter-trial interval
NREM	non-rapid eye movement
PET	Personal Efficiency Trainer
PRS	post-reinforcement synchronization
QEEG	quantitative electroencephalogram
SCP	slow cortical potential
SMR	sensorimotor rhythm
SPSS	statistical package for the social sciences
TFT	thin film transistor
TTD	Thought Translation Device
U	'up' trial – SCP negativity-required; SMR suppression-required

References

- Baehr, E., Rosenfeld, J.P., & Baehr, R. (2001). Clinical use of an alpha asymmetry neurofeedback protocol in the treatment of mood disorders: Follow-up study one to five years post therapy. *Journal of Neurotherapy*, 4(4), 11-18.
- Bazhenov, M., Timofeev, I., Steriade, M., & Sejnovski, T.J. (1999). Self-sustained rhythmic activity in the thalamic reticular nucleus mediated by depolarizing GABA_A receptor potentials. *Nature Neuroscience*, 2(2), 168-174.
- Birbaumer, N., Elbert, T., Rockstroh, B., & Lutzenberger, W. (1981). Biofeedback of event-related slow potentials of the brain. North Holland Publishing Company, pp. 389-413, 1981.
- Birbaumer, N., Elbert, T., Canavan, A.G.M., & Rockstroh, B. (1990). Slow potentials of the cerebral cortex and behavior. *Physiological Reviews*, 70(1), 3-41.
- Birbaumer, N., Flor, H., Ghanayim, N., Hinterberger, T., Iverson, I., Taub, E., Kotchoubey, B., Kübler, A., & Perelmouter, J. (1999). A spelling device for the paralyzed. *Nature*, 398, 297-298.
- Buchwald, N.A., Horvath, F.E., Wyers, E.J., & Wakefield, C. (1964). Electroencephalogram rhythms correlated with milk reinforcements in cats. *Nature*, 201, 830-831.
- Clemente, C.D., Serman, M.B., & Wyrwicka, W. (1964). Post-reinforcement EEG synchronization during alimentary behavior. *Electroencephalography and Clinical Neurophysiology*, 16, 355-365.
- Egner, T., & Gruzelier, J.H. (2003). EEG biofeedback of low beta band components: frequency-specific effects on variables of attention and event-related brain potentials. *Clinical Neurophysiology*, 115, 131-139.
- Elbert, T., Rockstroh, B., Lutzenberger, W., & Birbaumer, N. (1980). Biofeedback of slow cortical potentials. *Electroencephalography and Clinical Neurophysiology*, 48, 293-301.
- Elbert, T. (1993). Slow cortical potentials reflect the regulation of cortical excitability. In McCallum, W.C., & Curry, S.H. (Eds.). *Slow potential changes in the human brain*. Plenum Press, New York, 1993, 235-251.
- Ferster, C.B., & Skinner, B.F. (1957). *Schedules of reinforcement*. New York: Appleton-Century-Crofts.
- Finley, W.W., Smith, H.A., & Etherton, M. D. (1975). Reduction of seizures and normalization of the EEG in a severe epileptic following sensorimotor biofeedback training: Preliminary study. *Biological Psychiatry*, 2, 189-203.

Gratton, G., Coles, M.G.H., & Donchin, E. (1983). A new method for off-line removal of ocular artifact. *Electroencephalography and Clinical Neurophysiology*, 55, 468-484.

Hammond, D.C. (2005). Neurofeedback with anxiety and affective disorders. *Child & Adolescent Psychiatric Clinics of North America*, 14(1), 105-123.

Hardt, J.V., & Kamiya, J. (1978). Anxiety change through encephalographic alpha feedback seen only in high anxiety subjects. *Science*, 201, 79-81.

Hinterberger, T., Neumann, N., Pham, M., Kübler, A., Grether, A., Hofmayer, N., Wilhelm, B., Flor, H., & Birbaumer, N. (2004). A multimodal brain-based feedback and communication system. *Experimental Brain Research*, 154(4), 521-6.

Ikeda, A., Taki, W., Kunieda, T., Terada, K., Mikuni, N., Nagamine, T., Yazawa, S., Ohara, S., Hori, T., Kaji, R., Kimura, J., & Shibasaki, H. (1999). Focal ictal direct current shifts in human epilepsy as studied by subdural and scalp recording. *Brain*, 122(5), 827-838.

Kaiser, J., Perelmouter, J., Iversen, I.H., Neumann, N., Ghanayima, N., Hinterberger, T., Kübler, A., Kotchoubey, B., & Birbaumer, N. (2001). Self-initiation of EEG-based communication in paralyzed patients. *Clinical Neurophysiology*, 112, 551-554.

Kleinman, K.M. (1981). The role of reinforcement and motivation in biofeedback performance. *Physiology and Behavior*, 26(5), 921-925.

Kotchoubey, B., Schneider, D., Schleichert, H., Strehl, U., Uhlmann, C., Blankenhorn, V., Froscher, W., & Birbaumer, N. (1996). Self-regulation of slow cortical potentials in epilepsy: A retrieval with analysis of influencing factors. *Epilepsy Research*, 25, 269-276.

Kotchoubey, B., Schleichert, H., Lutzenberger, W., & Birbaumer, N. (1997). A new method for self-regulation of slow cortical potentials in a timed paradigm. *Applied Psychophysiology and Biofeedback*, 22(2), 77-93.

Kotchoubey, B., Busch, S., Strehl, U., & Birbaumer, N. (1999). Changes in EEG power spectra during biofeedback of slow cortical potentials in epilepsy. *Applied Psychophysiology and Biofeedback*, 24(4), 213-233.

Kotchoubey, B., Strehl, U., Uhlmann, C., Holzapfel, S., König, M., Froscher, W., Blankenhorn, V., & Birbaumer, N. (2001). Modification of slow cortical potentials in patients with refractory epilepsy: A controlled outcome study. *Epilepsia*, 42(3), 406-416.

Kropotov, J.D., Grin-Yatsenko, V.A., Ponomarev, V.A., Chutko, L.S., Yakovenko, E.A., & Nikishina, I.S. (2005). ERPs correlates of EEG relative beta training in ADHD children. *International Journal of Psychophysiology*, 55, 23-34.

Kübler, A., Kotchoubey, B., Hinterberger, T., Ghanayim, N., Perelmouter, J., Schauer, M., Fritsch, C., Taub, E., & Birbaumer, N. (1999). The thought translation device: a

neurophysiological approach to communication in total motor paralysis. *Experimental Brain Research*, 124, 223–232.

Kübler, A., Kotchoubey, B., Kaiser, J., Wolpaw, J.R., & Birbaumer, N. (2001). Brain-computer communication: unlocking the locked in. *Psychological Bulletin*, 127(3), 358–375.

Kübler, A., Nijboer, F., Mellinger, J., Vaughan, T.M., Pawelzik, H., Schalk, G., McFarland, D.J., Birbaumer, N., & Wolpaw, J.R. (2005). Patients with ALS can use sensorimotor rhythms to operate a brain-computer interface. *Neurology*, 64, 1775–1777.

Kuhlman, W.N., & Allison, T. (1978). EEG feedback training in the treatment of epilepsy: Some questions and some answers. *Pavlovian Journal of Biological Science*, 12(2), 112–122.

Lantz, D. L., & Serman, M. B. (1988). Neuropsychological assessment of subjects with uncontrolled epilepsy: Effects of EEG feedback training. *Epilepsia*, 29, 163-171.

Lal, S.K.L., Henderson, R.J., Carter, N., Bath, A., Hart, M.G., Langeluddecke, P., & Hunyor, S.N. (1998). Effect of feedback signal and psychological characteristics on blood pressure self-manipulation capability. *Psychophysiology*, 35, 405-412.

Lubar, J.O., & Lubar, J.F. (1984). Electroencephalographic biofeedback of SMR and beta for treatment of attention deficit disorders in a clinical setting. *Biofeedback and Self-Regulation*, 9(1), 1-23.

Lubar, J.F., Swartwood, M.O., Swartwood, J.N., & O'Donnell, P.H. (1995). Evaluation of the effectiveness of EEG neurofeedback training for ADHD in a clinical setting as measured by changes in T.O.V.A. scores, behavioral ratings, and WISC-R performance. *Biofeedback & Self-Regulation*, 20(1), 83-99.

Malenka, R.C., & Nicoll, R.A. (1999). Long-term potentiation – a decade of progress? *Science* 285, 1870-1874.

McFarland, D.J., Sarnacki, W.A., Vaughan, T.M., & Wolpaw, J.R. (2005). Brain-computer interface (BCI) operation: signal and noise during early training sessions. *Clinical neurophysiology*, 116, 56-62.

Mohr, B., Pulvermüller, F., & Schleicher, H. (1998). Learned changes of brain state alter cognitive processing in humans. *Neuroscience Letters*, 253, 159-162.

Monastera, V.J., Lynn, S., Linden, M., Lubar, J.F., Gruzelier, J., & LaVaque, T.J. (2005). Electroencephalographic biofeedback in the treatment of attention-deficit/hyperactivity disorder. *Applied Psychophysiology & Biofeedback*, 27(4), 231-249.

Neumann, N., & Birbaumer, N. (2003). Predictors of successful self control during brain-computer communication. *Journal of Neurology, Neurosurgery and Psychiatry*, 74(8), 1117-1121.

Neumann, N., Hinterberger, T., Kaiser, J., Leins, U., Birbaumer, N., & Kübler, A. (2004). Automatic processing of self-regulation of slow cortical potentials: evidence from brain-computer communication in paralyzed patients. *Clinical Neurophysiology*, 115, 628-635.

Parente, A. & Parente, R. (2006). Mind-operated devices: mental control of a computer using biofeedback. *Cyberpsychology and Behavior*, 9(1), 1-4.

Pfurtscheller, G. (1992). Event-related synchronization (ERS): An electrophysiological correlate of cortical areas at rest. *Electroencephalography and Clinical Neurophysiology*, 83, 62-69.

Pfurtscheller, G., Flotzinger, D., & Kalcher, J. (1993). Brain-computer interface – a new communication device for handicapped persons. *Journal of Microcomputer Applications*, 16, 293-299.

Pfurtscheller G., Flotzinger D., Pregenzer W., Wolpaw J.R., & McFarland D.J. (1996). EEG-based brain-computer interface (BCI): search for optimal electrode positions and frequency components. *Medical Progress through Technology*, 21, 111-121.

Pfurtscheller, G., Neuper, Ch., Flotzinger, D., & Pregenzer, M. (1997). EEG-based discrimination between imagination of right and left hand movement. *Electroencephalography and Clinical Neurophysiology*, 103, 642-651.

Pfurtscheller, G., Brunner, C., Schlögl, A., & Lopes da Silva, F.H. (2006). Mu rhythm (de)synchronization and EEG single-trial classification of different motor imagery tasks. *NeuroImage*, 31, 153-159.

Pham, M., Hinterberger, T., Neumann, N., Kübler, A., Hofmayer, N., Grether, A., Wilhelm, B., Vatine, J.J., & Birbaumer, N. (2005). An auditory brain-computer interface based on the self-regulation of slow cortical potentials. *Neurorehabilitation and Neural Repair*, 19(3), 206-218.

Rockstroh, B., Elbert, T., Birbaumer, N., & Lutzenberger, W. (1990). Biofeedback-produced hemispheric asymmetry of slow cortical potentials and its behavioral effects. *International Journal of Psychophysiology*, 9, 151-165.

Rockstroh, B., Elbert, T., Birbaumer, N., Wolf, P., Duchting-Roth, A., Reker, M., Daum, I., Lutzenberger, W., & Dichgans, J. (1993). Cortical self-regulation in patients with epilepsies. *Epilepsy Research*, 14(1), 63-72.

Rösler, F., Heil, M., & Röder, B. (1997). Slow negative brain potentials as reflections of specific modular resources of cognition. *Biological Psychology*, 45, 109-141.

Scolnick, B. (2005). Effects of electroencephalogram biofeedback with Asperger's syndrome. *International Journal of Rehabilitation Research*, 28(2), 159-163.

Seifert, A.R., & Lubar, J.F. (1975). Reduction of epileptic seizures through EEG biofeedback training. *Biological Psychology*, 3, 157-184.

Siniatchkin, M., Kropp, P. & Gerber, W.D. (2000). Neurofeedback: the significance of reinforcement and the search for an appropriate strategy for the success of self-regulation. *Applied Psychophysiology and Biofeedback*, 25(3), 168-175.

Skinner, B.F. (1975). The shaping of phylogenic behavior. *Journal of the Experimental Analysis of Behavior*, 24(1), 117-120.

Spronk, D.B., Arns, M.W., Kleinnijenhuis, M., Breteler, M.H.M., & van Luijtelaar, G. (in preparation).

Sterman, M.B., & Friar, L. (1972). Suppression of seizures in an epileptic following sensorimotor EEG feedback training. *Electroencephalography and Clinical Neurophysiology*, 1, 57-86.

Sterman, M.B., MacDonald, L.R., & Stone, R.K. (1974). Biofeedback training of the sensorimotor EEG rhythm in man: Effects on epilepsy. *Epilepsia*, 15, 395-417.

Sterman, M.B. & MacDonald, L.R., (1978). Effects of central cortical EEG feedback training on incidence of poorly controlled seizures. *Epilepsia*, 19, 207-222.

Sterman, M.B. & Shouse, M.N., (1980). Quantitative analysis of training, sleep EEG and clinical response to EEG operant conditioning in epileptics. *Electroencephalography and Clinical Neurophysiology*, 49(5-6), 558-76.

Sterman, M.B. (1984). The role of the sensorimotor EEG activity in the etiology and treatment of generalized motor seizures. In T. Elbert, B. Rockstroh, W. Lutzenberger, & N. Birbaumer (Eds.), *Self-regulation of the brain and behavior* (pp. 95-106). Berlin: Springer.

Sterman, M.B. (2000). Basic concepts and clinical findings in the treatment of seizure disorders with EEG operant conditioning. *Clinical Electroencephalography*, 31(1), 45-55.

Sterman, M.B., & Egner, T. (2006). Foundation and practice of neurofeedback for the treatment of epilepsy. *Applied Psychophysiology and Biofeedback*, 31(1), 21-35.

Storm van Leeuwen, W., Wieneke, G., Spoelstra, P., & Versteeg, H. (1978). Lack of bilateral coherence of mu rhythm. *Electroencephalography and Clinical Neurophysiology*, 44, 140-146.

Strehl, U., Trevorrow, T., Veit, R., Hinterberger, T., Kotchoubey, B., Erb, M., & Birbaumer, N. (2006). Deactivation of brain areas during self-regulation of slow cortical potentials in seizure patients. *Applied Psychophysiology and Biofeedback*, 31(1), 85-94.

Tansey, M.A. (1986). A simple and a complex tic (Gilles de la Tourette's syndrome): their response to EEG sensorimotor rhythm biofeedback training. *International Journal of Psychophysiology*, 4, 91-97.

Tozzo, C.A., Elfner, L.F., & May Jr., J.G. (1988). EEG Biofeedback and relaxation training in the control of epileptic seizures. *International Journal of Psychophysiology*, 6, 185-194.

Vernon, D., Egner, T., Cooper, N., Compton, T., Neilands, C., Sheri, A., & Gruzelier, J. (2003). The effect of training distinct neurofeedback protocols on aspects of cognitive performance. *International Journal of Psychophysiology*, 47, 75-85.

Wolpaw, J.R., Birbaumer, N., McFarland, D.J., Pfurtscheller, G., & Vaughan, T.M. (2002). Brain-computer interfaces for communication and control. *Clinical Neurophysiology*, 113, 767-791.

Wyler, A.R., Robbins, C.A., & Dodrill, C.B. (1976). EEG operant conditioning for control of epilepsy. *Epilepsia*, 20, 279-286.

Wyrwicka, W., & Serman, M.B. (1968). Instrumental conditioning of sensorimotor cortex EEG spindles in the waking cat. *Physiology and Behavior*, 3, 703-707.